

FISHERIES DIVISION
RESEARCH REPORT

Number 2001

June 30, 1995

**Vegetation-Open Water Interface and the
Predator-Prey Interaction Between Largemouth
Bass and Bluegills: An Encounter Model**

Kelley D. Smith

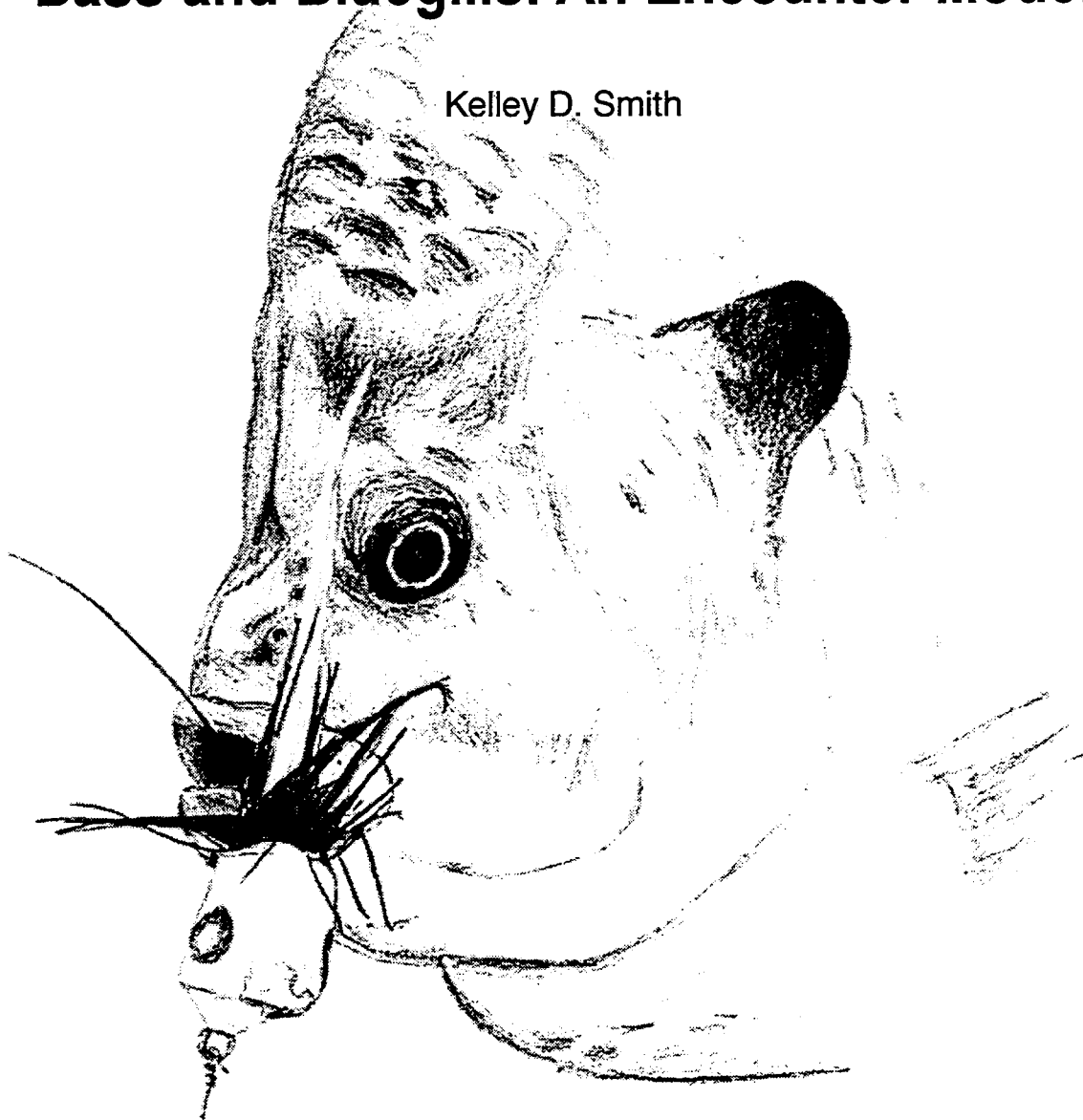

STATE OF MICHIGAN
DEPARTMENT OF NATURAL RESOURCES

**MICHIGAN DEPARTMENT OF NATURAL RESOURCES
FISHERIES DIVISION**

**Fisheries Research Report 2001
June 30, 1995**

**VEGETATION - OPEN WATER INTERFACE AND THE PREDATOR - PREY
INTERACTION BETWEEN LARGEMOUTH BASS AND BLUEGILLS:
AN ENCOUNTER MODEL**

Kelley D. Smith



The Michigan Department of Natural Resources, (MDNR) provides equal opportunities for employment and for access to Michigan's natural resources. State and Federal laws prohibit discrimination on the basis of race, color, sex, national origin, religion, disability, age, marital status, height and weight. If you believe that you have been discriminated against in any program, activity or facility, please write the MDNR Equal Opportunity Office, P.O. Box 30028, Lansing, MI 48909, or the Michigan Department of Civil Rights, 1200 6th Avenue, Detroit, MI 48226, or the Office of Human Resources, U.S. Fish and Wildlife Service, Washington D.C. 20204.

For more information about this publication or the American Disabilities Act (ADA), contact, Michigan Department of Natural Resources, Fisheries Division, Box 30446, Lansing, MI 48909, or call 517-373-1280.

Cover sketch was done by Andrea Clark. TOTAL COPIES PRINTED: 300; TOTAL PRINTING COST: \$508.00 COST PER COPY: \$1.69

Vegetation-Open Water Interface and the Predator-Prey Interaction between Largemouth Bass and Bluegills: an Encounter Model

Kelley D. Smith¹

*The University of Michigan
School of Natural Resources and Environment
Ann Arbor, Michigan 48109*

Abstract.—A mathematical model was developed to estimate numbers of bluegills *Lepomis macrochirus* encountered by largemouth bass *Micropterus salmoides* in enclosures which contained 30 feet of vegetation-open water interface (or edge) and 60 feet of edge, as used previously in a field experiment. Edge was originally created in one enclosure by removing a single strip of vegetation 6-feet wide and 15-feet long from the middle (1S enclosure), and in the other by removing two strips 3-feet wide by 15-feet long at 3-foot intervals (2S). In the model, capture probabilities were assumed to be constant and independent of amount of edge. Results of model runs suggested that edge effects would double numbers of bluegills encountered in the 2S enclosure compared to the 1S, under certain conditions of light intensity, assumed bluegill behavior, and bass position in open water between vegetated plots. Spatial distribution of bluegills in both enclosures were identical in these simulations. However, bluegill behavior may be affected by both width of open water between refuges and perceived density of bass in the immediate locale. Model results supported this possibility since predicted numbers encountered were sensitive to subtle changes in assumed behaviors of bluegills in different enclosures. These results demonstrate that the main effect of edge is likely related to changes in number of bluegills encountered by bass. Second, reactions to predation risk on a diel scale may cause behavioral responses by bluegills that are difficult to measure, but which significantly alter their ability to avoid detection. Third, effects of light intensity on the ability of bass and bluegills to see each other has important implications for determining when bass of certain sizes would be most efficient in actively searching for bluegills. An algorithm to estimate suitable open water widths when creating edge will need to incorporate knowledge of bass reaction distances to bluegills, size structure of bass and bluegill populations, bass foraging tactics including temporal and spatial aspects of foraging strategies, and bluegill behavioral responses to their environment.

Encountering prey is the first required step a predator must take if it is to forage successfully, and thus survive and grow. All other behaviors (follow, attack, pursuit, and capture) exhibited by a predator during an

interaction with a prey species can only occur after a predator effectively establishes contact with its prey. Visual contact with prey can be affected by many factors, including predator behavior (Savino and Stein 1989b), prey

¹Present address: Michigan Department of Natural Resources, Charlevoix Great Lakes Research Station, 97 Grant Street, Charlevoix, Michigan 49720.

behavior (Snyder 1967; Stein and Magnuson 1976; Savino and Stein 1982), structural complexity (Glass 1971; Crowder and Cooper 1979; Anderson 1984), and light intensity (Howick and O'Brien 1983). Effects of light intensity are further confounded by water clarity (Johnson et al. 1988), physical or background shading of predator and/or prey (Helfman 1979; Endler 1986), and size of individuals interacting (Howick and O'Brien 1983). Although visual aptitude varies between predators and may or may not have important consequences on outcomes of a predator-prey interaction (Endler 1986), it is critical in determining rates at which largemouth bass *Micropterus salmoides* encounter prey items (Nyberg 1971).

A field experiment to determine effects of manipulating vegetation-open sediment interface (or edge) on the predator-prey interaction between largemouth bass and bluegills *Lepomis macrochirus* clearly demonstrated a positive correlation between edge and predation success for 8- and 11-inch bass (total length, TL) preying on bluegills (Smith 1993b). Yet, reasons for these results and the fact that predation rates averaged 4.4 times greater when the amount of edge was doubled, rather than 2.0 times as originally expected, are not clear. In Smith (1993b), I hypothesized that the unexpected magnitude of differences was probably attributable to effects of edge on encounter rates rather than on capture probabilities. The factors most important in determining relative changes in encounter rates for bass were related to effects of open water widths between refuges on distances at which bass react to bluegills, and behavioral responses by bluegills to associate more strongly with edge in certain habitat types. Behavior of bluegills was assumed to be a function of an individual bluegill's reaction to predation risk in open water areas, which in turn is influenced by bluegill size, bass density, bass size, and distance between refuges (Werner et al. 1983; Werner and Hall 1988). Factors affecting

bass behavior (e.g., interference and social facilitation) were deemed to be less important, and possibly insignificant, in affecting their own ability to encounter bluegills. However, this explanation implies that the probability of bass capturing bluegills must be independent of amount of edge, and therefore must be constant in the two habitat types. Since quantifiable observations of the bass-bluegill interaction were not possible during the field experiment, mathematical analyses of the interaction can aid in determining if edge effects on encounter rates can singularly explain field results, assuming constant capture probabilities.

An understanding of how predators locate and attack their prey and how prey respond to predators is essential for developing an analytical description of predator-prey interactions. A great amount of investigation has gone into determining what operative mechanisms control predator-prey interactions in aquatic systems (Glass 1971; Nyberg 1971; Savino and Stein 1982; Howick and O'Brien 1983; Webb 1986; Savino and Stein 1989a, 1989b), and analyzing such mechanisms using mathematical models (Holling 1966; Glass 1971; Paloheimo 1971a, 1971b; Fujii et al. 1978; Hassell 1978; DeAngelis et al. 1984; Kerfoot and Sih 1987). Models of predator-prey dynamics have been based on general descriptions of search and attack (Gause 1934; Watt 1959; Paloheimo 1971a, 1971b; Hassell et al. 1977), relationships between quantity of different foods a predator consumes and food preference and abundance (Marten 1973; DeAngelis et al. 1984), and predictions of predator diet as a function of visual acuity (i.e., reactive field volume versus apparent size), energy demands, or optimal foraging constraints (Glass 1971; Werner and Hall 1974; O'Brien et al. 1976; Mittelbach 1981; Eggers 1982; Anderson 1984; Wetterer and Bishop 1985). Models have also been used to examine specific components of predatory interactions, including effects of morphology

and behavior of predators on their ability to attack prey (Nyberg 1971; Webb 1984), avoidance and evasion of predators by prey (Webb 1982, 1986; Weihs and Webb 1984; Endler 1986; Helfman 1986), and effects of vegetation density on behavior and success of predators (Glass 1971; Savino and Stein 1982; Gotceitas and Colgan 1987, 1990).

A simple and widely used attack model is the disc equation developed by Holling (1959). It describes basic components of a predatory interaction (encounter, pursuit, attack, and capture), each of which has some associated probability of success. Modifications of the model have been used to examine a variety of factors which affect attack success, for example predator interference, predator learning, and prey dispersion (see Fujii et al. 1978 for a review). The basic form of the model is derived as:

$$A(N_0) = a \cdot T_s \cdot N_0; \quad (1)$$

$$T_t = T_s + t_h \cdot A(N_0); \quad (2)$$

$$A(N_0) = a \cdot (T_t - t_h \cdot A(N_0)) \cdot N_0; \quad (3)$$

$$\begin{aligned} A(N_0) &= \frac{a \cdot T_t \cdot N_0}{1 + a \cdot t_h \cdot N_0}; \\ &= \frac{T_t}{t_h + \frac{1}{a \cdot N_0}}; \end{aligned} \quad (4)$$

$A(N_0)$ is the average number of prey attacked per predator during time T_t as a function of prey density; N_0 is prey density; a is the rate of a successful search; T_t is the total time prey are exposed to a predator; T_s is the total time spent searching by a predator; and t_h is the average time spent by a predator in handling an individual prey item (pursuing,

capturing, and eating). Equation (4) implies that pursuit, attack, and capture are constant and independent of prey density, while encounter (a above) is directly proportional to prey density. This is further demonstrated by taking limits of (4):

$$\lim_{N_0 \rightarrow 0} A(N_0) = 0; \quad (5)$$

$$\lim_{N_0 \rightarrow \infty} A(N_0) = \frac{T_t}{t_h} = A_{\max}. \quad (6)$$

Given this formulation, I will assume that increasing amounts of edge should not affect the ability of bass to pursue, attack, and capture bluegills. This contrasts with what occurs when structural complexity is defined by vegetation density. In this case, probabilities of pursuit, attack, and capture decrease as density of vegetation is increased because more barriers (plants) exist which inhibit predators (Glass 1971; Savino and Stein 1982). But, if structure is defined as amount of edge available, and assuming that predatory interactions most likely occur in open water areas between weed beds, then these probabilities should not be affected by changes in complexity (Nyberg 1971; Webb 1986). Thus, ability of bass to encounter bluegills may be the component of the predator-prey interaction which is most sensitive to changes in amount of edge in a system.

One possible alteration of Holling's model demonstrates edge effects on encounter rates (note: such a model assumes that amount of edge in a system can be quantified in some way). Assume that the average number of prey attacked per predator during time T_t , as a function of prey density and amount of edge, is described by:

$$A(N_0, E_0) = (a - \beta \cdot \alpha^{E_0}) \cdot T_s \cdot N_0. \quad (7)$$

Then, using the equality in (2):

$$A(N_0, E_0) = \frac{(a - \beta \cdot \alpha^{E_0}) \cdot (T_t - t_h \cdot A(N_0, E_0)) \cdot N_0}{(T_t - t_h \cdot A(N_0, E_0)) \cdot N_0}; \quad (8)$$

$$\begin{aligned} A(N_0, E_0) &= \frac{(a - \beta \cdot \alpha^{E_0}) \cdot T_t \cdot N_0}{1 + (a - \beta \cdot \alpha^{E_0}) \cdot t_h \cdot N_0}; \\ &= \frac{T_t}{t_h + \frac{1}{(a - \beta \cdot \alpha^{E_0}) \cdot N_0}}; \quad (9) \end{aligned}$$

$A(N_0, E_0)$ is the average number of prey attacked per predator during time T_t as a function of prey density and edge; E_0 is amount of edge in a system ($E_0 = 0$ implies no edge or complete vegetation, $E_0 = \infty$ implies infinite edge or no vegetation); β is the decrease in the rate of a successful search caused by edge effects ($\beta \leq a$); α proportions the decrease in the rate of a successful search (β), depending on the amount of edge ($0 < \alpha < 1$); and all other parameters are as described in (4). Taking limits of (9) gives:

$$\lim_{E_0 \rightarrow 0} A(N_0, E_0) = \frac{T_t}{t_h + \frac{1}{(a - \beta) \cdot N_0}}; \quad (10)$$

$$\lim_{E_0 \rightarrow \infty} A(N_0, E_0) = \frac{T_t}{t_h + \frac{1}{a \cdot N_0}} = (4); \quad (11)$$

$$\lim_{N_0 \rightarrow 0} A(N_0, 0) = 0; \quad (12)$$

$$\lim_{N_0 \rightarrow 0} A(N_0, \infty) = 0 = (5); \quad (13)$$

$$\lim_{N_0 \rightarrow \infty} A(N_0, 0) = \frac{T_t}{t_h} = A_{\max}; \quad (14)$$

$$\lim_{N_0 \rightarrow \infty} A(N_0, \infty) = \frac{T_t}{t_h} = A_{\max} = (6). \quad (15)$$

The model has appropriate qualities to relate number of attacks to both prey density and amount of edge. Equation (9) is equivalent to (4) if edge is ignored (by (11), (13), and (15)). It also demonstrates that decreasing amounts of edge in a system lead to fewer attacks on prey, because of a reduction in the rate of a successful search by a predator. This mathematical description of attack success is consistent with my explanation for results of the field experiment (Smith 1993b). Hence, the objective of this study is the development of a model to analyze effects of edge on the ability of bass to encounter bluegills, given that capture probabilities are constant and do not affect the interaction. I hypothesize that changes in amount of edge impact predation rates by modifying prey exposure, and thus the probability that bass will encounter bluegills. The model calculates an expected number of bluegills encountered at some time t as a function of bass size and location in an enclosure, bluegill size and behavior, and light intensity. Various distributions are employed to describe the behavioral response of bluegills reacting to predation risk in an open water habitat, as a function of the distance traveled from an edge of a refuge.

Methods

A mathematical model was developed to estimate numbers of bluegills encountered by largemouth bass in two enclosures which contained edge, as used in the field experiment described in Smith (1993b). Edge was originally created in one enclosure by removing a single strip of vegetation 6-foot wide and 15-foot long from the middle to create 30 feet of edge (1S enclosure), and in the other by removing two strips 3-foot wide

by 15-foot long at 3-foot intervals to create 60 feet of edge (2S). Since capture probabilities are assumed to be constant and independent of amount of edge, how well model predictions fit results from field trials reported in Smith (1993b) was determined by the magnitude of differences between estimated numbers of bluegills encountered in the 2S and 1S enclosures. If ratios of the numbers encountered (2S/1S) were similar to ratios between predation rates observed in the field experiment and reported in Smith (1993b), then a given scenario was assumed to be adequate in describing dynamics of the predator-prey interaction. Several scenarios were tested given different conditions of light intensity, bass and bluegill size, and their behavior and spatial distribution.

If the probability that a bass of size i detects an individual bluegill of size j is a Bernoulli trial, then each bluegill is encountered with a probability $p_{i,j}$ or not encountered with a probability $q_{i,j}$. If bluegills are randomly and independently distributed within an enclosure, then the probability that a bass of size i encounters an individual bluegill of size j is:

$$p_{i,j} = \frac{R_{v,i,j}}{T_v},$$

because a bass is searching this fraction of an enclosure, where $R_{v,i,j}$ is the reaction volume of a bass of size i to a bluegill of size j , and T_v is the total volume in which bass and bluegills reside. The probability of not encountering that individual bluegill is:

$$q_{i,j} = 1 - p_{i,j}.$$

Given that there are N prey of size j randomly and independently distributed in an enclosure, the probability that a bass of size i encounters none of these bluegills is $q_{i,j}^N$, and the probability that a bass encounters at

least one bluegill is $1 - q_{i,j}^N$. Thus, the probability that a bass of size i will encounter k prey, given that N bluegills of size j are present in an enclosure, is described by the binomial distribution:

$$P(k \text{ encountered})_{i,j} = \frac{N!}{k! \cdot (N-k)!} \cdot p_{i,j}^k \cdot q_{i,j}^{N-k}.$$

The mean number of prey of size j which are encountered by a bass of size i , given N_j bluegills in an enclosure, is:

$$\bar{E}_{i,j} = p_{i,j} \cdot N_j = \frac{R_{v,i,j} \cdot N_j}{T_v}.$$

Summing these mean numbers encountered over all prey sizes j which are available in T_v gives the expected number of bluegills encountered ($E(E)$) by a bass of size i :

$$E(E)_i = \sum_j \bar{E}_{i,j} = \sum_j p_{i,j} \cdot N_j = \frac{\sum_j R_{v,i,j} \cdot N_j}{T_v}.$$

This is the method used in the encounter model. Reaction volume of a bass is assumed to be spherical (see e.g., Paloheimo 1971a; Eggers 1982; Wetterer and Bishop 1985), and is defined to be one-quarter of a sphere with radius r , in the positive Y and Z quadrants and both X quadrants (Figure 1). The volume can be truncated on the left and right sides of a bass (positive and negative X quadrants) by weeds, which create visual barriers that are parallel to the body of the fish (Z -axis). Weeds (left and right) may not be equidistant from a bass when it is at some position $(x, 0, 0)$. The reaction volume can also be truncated above a bass (positive Y quadrant) by the water surface.

Let w denote a point on the right side of a bass at which weeds create a visual barrier perpendicular to the X -axis. The distance from a bass to the weed edge is W , or w since $w - 0 = W$. Let s denote a point above a bass at which the water surface creates a visual barrier perpendicular to the Y -axis. The distance from a bass to the water surface is S , or s since $s - 0 = S$. This leads to 5 cases which describe the reaction volume depending on location of a bass in an enclosure, and distance at which it reacts to a bluegill of a given size (see Appendices A-F in Smith (1993a) for derivations of these solutions):

- 1) $w - r \geq 0$ and $s - r \geq 0$; volume of one-eighth of a sphere of radius r with no truncation (Appendix A in Smith (1993a)).
- 2) $w - r < 0$ and $s - r \geq 0$; volume of one-eighth of a sphere of radius r truncated along the X -axis by a plane parallel to the Y - Z axes through w (weed edge truncation; Figure 2, panel (a); Appendix B in Smith (1993a)).
- 3) $w - r \geq 0$ and $s - r < 0$; volume of one-eighth of a sphere of radius r truncated along the Y -axis by a plane parallel to the X - Z axes through s (water surface truncation; Figure 2, panel(b); Appendix C in Smith (1993a)).
- 4) $w - r < 0$ and $s - r < 0$; volume of one-eighth of a sphere of radius r truncated along the X -axis by a plane parallel to the Y - Z axes through w and along the Y -axis by a plane parallel to the X - Z axes through s (weed edge and water surface truncation), which includes two final possibilities:
 - a) $w^2 + s^2 \geq r^2$; intersection of the two planes occurs outside the sphere (Figure 2, panel(c); Appendix D in Smith (1993a)).
 - b) $w^2 + s^2 < r^2$; intersection of the two planes occurs inside the sphere (Figure 1; Figure 2, panel (d);

Appendices E and F in Smith (1993a)).

Regression equations were developed for predicting distances at which largemouth bass react to bluegills (radius of a reaction volume, r). Data from Howick and O'Brien (1983) for reaction distance (RD) of bass to motionless bluegills were analyzed using stepwise multiple regression (Neter and Wasserman 1974). Independent variables included bass size, bluegill size, and light intensity. Equations to predict distances at which bluegills react to bass were developed using the same statistical procedure. However, only bass size and light intensity were included as independent variables in this analysis, since size of a bluegill does not affect its ability to detect bass of any size. Parameters for RD equations were estimated assuming conditions of bright daylight (3,340 lux) and twilight (1.49 lux).

Prey behavior was simulated by defining hypothetical distributions which describe bluegills' reaction to predation risk in open water areas of an enclosure. Four distributions were used to characterize a wide range of behaviors by relating distances traveled from an edge of a refuge to size of an individual bluegill (Crowder and Cooper 1979). The premise that predation risk moderates behavior of bluegills on a diel scale has been shown in laboratory trials (Gotceitas and Colgan 1987, 1990). It is also analogous to observations of bluegill behavior and spatial distribution on an ontogenetic scale, as reported by Mittelbach (1981), Werner et al. (1983), and Werner and Hall (1988). The first distribution assumes that bluegills are distributed uniformly throughout all vegetated areas of an enclosure and some portion of an open water area, implying that behavioral responses exhibited by bluegills in reaction to predation risk are independent of their size. In these simulations, $E(E)$ s were calculated for each 1" interval of distance traveled by bluegills of all sizes into open

water, up to the maximum width (36") of an open water area in the 2S habitat type. The remaining distributions relate distance moved from an edge to bluegill size (Figure 3), and include:

$$\text{Monotonic increase to an asymptote} \quad D = m \cdot (1 - e^{-\rho \cdot (L - n)});$$

$$\text{Sigmoid} \quad D = \frac{m}{(1 + n \cdot \rho^L)};$$

$$\text{Exponential} \quad D = m \cdot e^{n \cdot L};$$

D is distance (inches) traveled from an edge of the weeds; L is size of a bluegill (inches, TL); and m , n , and ρ are parameters of the equations. Two different forms of these functions were simulated such that the largest sized bluegill (4.9") was willing to travel 18 or 36 inches from an edge.

Model runs were also made to determine how sensitive estimates of $E(E)$ s are to changes in width of open water areas between weed beds. Two different habitat layouts were tested, assuming open water areas which were half and twice as wide as those used in the field experiment described in Smith (1993b): 1) an enclosure with one open area 36" wide versus an enclosure with two open areas 18" wide, and 2) an enclosure with a single open area 144" wide versus an enclosure with two open areas 72" wide. Total volume was still assumed to be equivalent to that for enclosures used in field trials (Smith 1993b).

Assumptions

Assumptions concerning definition of a reaction volume of a bass, and behavior and spatial distributions of bass and bluegills in enclosures include:

- A bass is positioned at the center of the reaction volume such that point $(0, 0, 0)$ is centered between the eyes of the fish (Figure 1). The X -axis is perpendicular to the fish from its left to right side. The Y -axis is perpendicular to the fish from bottom to top of the water column. The Z -axis is parallel to the fish's body and edges created by vegetation.
- Reaction volume is truncated along the Z -axis by a plane parallel to the X - Y axes through $z = 0$, implying that a bass can not see behind itself.
- Reaction volume is truncated along the Y -axis by a plane parallel to the X - Z axes through $y = 0$, implying that a bass is on the lake bottom and can not see below itself.
- $E(E)$ s are estimated for some instant in time t , given that a bass is located at some point x in an open water area. Successive $E(E)$ s are calculated at each 1" interval of open water distance between weed beds, and are independent of previously estimated $E(E)$ s.
- There are two bass in each enclosure.
- When $E(E)$ s are estimated for bass in the 2S enclosure, each bass is located in separate open water areas. Thus, ability of one bass to encounter bluegills is not influenced by interference from a second bass.
- When $E(E)$ s are estimated in the 1S enclosure, both bass are located in the single open water area. Thus, both bass can not encounter the same bluegill simultaneously, implying complete interference between bass.
- Because a bluegill tends to freeze in place with the initial approach of a bass, distances at which bass react to bluegills were based on data for motionless prey (Howick and O'Brien 1983).
- If distance at which a bass reacts to a bluegill of a given size is less than that of the bluegill to the bass, then that bluegill is not included in the estimate of $E(E)$.

- Bluegills are encountered as individuals by bass, rather than as schools.
- Bluegill sizes range from 1.0- to 4.9-inches TL, in increments of one-tenth of an inch.
- Bluegill density in an enclosure is the same as that used in the field experiment; 38 small (1.0-2.9") and 12 large (3.0-4.9") bluegills (Smith 1993b).
- The largest bluegill which can be consumed by an 8-inch bass is 2.7 inches (Lawrence 1958; Wright 1970). Therefore, bluegills greater than 2.7" are not included in estimates of $E(E)$ for this size of bass.
- The largest bluegill which can be consumed by an 11-inch bass is 3.7 inches (Lawrence 1958; Wright 1970). Therefore, bluegills greater than 3.7" are not included in estimates of $E(E)$ for this size of bass.
- In the 2S enclosure, encounters of bluegills by bass may be increased if a bluegill under attack unwittingly fled through the middle strip of vegetation from one open area to another (Gotceitas and Colgan 1987). However, concepts of a critical refuge size and one bass aiding another were not included in the model. Thus, vegetation gives bluegills complete protection from bass, regardless of the width of vegetated areas available to fleeing bluegills.
- Reaction volumes of both bass and bluegills are unaffected by water clarity at any light intensity.
- Water depth in an enclosure is 3.5 feet.

Results

Largemouth bass size, bluegill size, and light intensity were all important in describing the distance at which bass react to motionless bluegills. No correlations were found between these three variables, and the estimated regression went through the origin. The regression was highly significant ($P < 0.01$), as were the parameter estimates for each of the three variables. Although

regressions reported by Howick and O'Brien (1983) to predict reaction distance (RD) of bass to bluegills were linear when each variable was treated independently, the best equation was curvilinear in form ($r^2 = 0.984$) when all three were treated together:

$$LN(RD) = 0.876 \cdot LN(\text{Bass size}) + 0.142 \cdot LN(\text{Light intensity}) + 0.370 \cdot \text{Bluegill size}.$$

Bass size explained 95.4% of the variation in bass RDs, followed by light intensity (2.3%) and bluegill size (0.9%).

Distances at which 8-inch bass react to bluegills in bright daylight (3,340 lux) ranged from 28.4" for a 1.0-inch bluegill to 120.2" for a 4.9-inch bluegill (Figure 4). Eight-inch bass could detect bluegills which were larger than 1.6" across the 36-inch wide open water area in the 2S habitat, and bluegills larger than 3.5" across the 72-inch wide open area in the 1S habitat. Eleven-inch bass had significantly greater RDs, ranging from 37.5" to 158.8" for 1.0- to 4.9-inch bluegills. In the 2S habitat, 11-inch bass could see all sizes of bluegills across the full width of an open water area, while in the 1S habitat this was true only for bluegills larger than 2.8".

In low light conditions (1.49 lux), RDs for both sizes of bass were greatly reduced (Figure 5). RDs of an 8-inch bass ranged from 9.5" for 1.0-inch bluegills to 40.1" for 4.9-inch bluegills. These distances exceeded an open area width in the 2S habitat only for bluegills larger than 4.6", and were never greater than width of an open strip in the 1S habitat for any size of bluegill. Eleven-inch bass RDs ranged from 12.5" to 53.0" for small to large bluegills. Therefore, 11-inch bass could detect bluegills larger than 3.9" across an open area in the 2S habitat, but could never detect bluegills of any size across the full width of an open area in the 1S habitat.

Distances at which bluegills react to largemouth bass are not affected by bluegill size (Howick and O'Brien 1983). Thus, only

bass size and light intensity were used in the regression analysis of bluegill RDs. As for bass RDs, no correlations were found between these two variables, the estimated regression went through the origin, regression and parameter estimates for each variable were highly significant ($P < 0.01$), and the best equation was curvilinear in form ($r^2 = 0.996$):

$$LN(RD) = 0.233 \cdot \text{Bass size} + 0.248 \cdot LN(\text{Light intensity}).$$

Bass size was again the most important variable, explaining 92.0% of the variation in bluegill RDs, while light intensity accounted for 7.7% of the total variation.

Since bluegill size is not important in estimating distances at which bluegills react to bass of varying sizes, a constant RD was calculated for each bass-size, light-level combination used in the model. Reaction distance of bluegills to 8-inch bass in daylight conditions was 48.2" (Figure 4). Thus, bluegills of all sizes would react to an 8-inch bass across the full width of an open strip in the 2S habitat, and more than half way across an open strip in the 1S. Also, bluegills that were smaller than 2.4" could see an 8-inch bass before the bass could see them. For 11-inch bass, the advantage for bluegills in bright light was even greater. With an RD of 96.7" to this size of bass, bluegills would detect 11-inch bass across open water areas in both habitats, and bluegills smaller than 3.6" would see the bass first.

Bluegill RDs to both sizes of bass were greatly reduced under low light conditions (Figure 5), averaging 7.1" and 14.2" for 8- and 11-inch bass, respectively. Thus, bluegills would never detect 8-inch bass first in low light, while only bluegills smaller than 1.3" would see 11-inch bass first.

The first set of simulation runs assumed that bluegill behavior could be described by a uniform distribution. This implies that reaction by bluegills to predation risk was

independent of bluegill size, and thus size of an individual bluegill was not important in regulating distances they would move into open water away from an edge of vegetation. Maximum number of bluegills encountered ($E(E)$) and position of a bass in an open water area (distance from a weed edge) at which these occurred were estimated for each inch of distance traveled by bluegills away from an edge.

Magnitude of differences in maximum $E(E)$ s between habitat types ($E(E)$ ratio, 2S/1S) for 8-inch bass under high light intensity decreased from 1.9 to 1.6 as distance traveled by bluegills from an edge increased from 1" to 18", after which ratios approached 2.0 (Figure 6). In low light conditions, ratios of maximum $E(E)$ s decreased from 1.0 to 0.8 as bluegill distance from an edge increased from 1" to 15", after which ratios approached 2.0 as for bright light simulations. Maximum numbers of bluegills encountered by 8-inch bass under low light conditions were only about one-quarter as large as those observed for bright light. Position of a bass in an open water area at which maximum $E(E)$ s occurred in the 2S habitat assuming bright light conditions was always 18" from an edge, or in the middle of an open strip, regardless of distance moved by bluegills. However, when light intensity was low, bass position which maximized $E(E)$ increased as bluegills traveled further from an edge, with a bass remaining close to an edge when bluegills did so and moving out towards a maximum position of 18" only when distance traveled by bluegills approached 36". This was also the case in simulations for 8-inch bass in the 1S habitat type regardless of light intensity.

Simulation results for 11-inch bass under bright light conditions were very similar to those for 8-inch bass (Figure 7). The shape and direction of $E(E)$ curves, bass behavior (position from an edge), and $E(E)$ ratios were identical. However, maximum numbers of bluegills encountered in both habitat types

were only half as large as those estimated for 8-inch bass.

Maximum $E(E)$ s for 11-inch bass under low light conditions were twice as great as those observed for this size of bass under bright light conditions, which was opposite of the situation for 8-inch bass. $E(E)$ s were also four times larger than estimates for 8-inch bass in twilight simulation, but $E(E)$ curves and simulated behavior of 11-inch bass in the 2S habitat were similar to that for smaller bass. Although position of a bass again increased to 18" as bluegills moved away from an edge, this position was reached and maintained when bluegills traveled 7" to 36" inches from an edge of vegetation as opposed to 18-36" for 8-inch bass. Bass position in the 1S habitat was analogous to that for 8-inch bass at 1.49 lux; increasing with prey movement from an edge. Maximum $E(E)$ ratios for 11-inch bass were quite different than those for 8-inch bass, decreasing from 1.0 to about 0.9 as bluegill distance from an edge increased from 1" to 6", after which ratios continuously increased toward a value of 2.0.

Light intensity, which significantly affects distances at which bass react to bluegills of varying size, was the most important factor affecting bass position and thus estimates of maximum $E(E)$ s and ratios between 2S and 1S habitat types. For example, estimated RDs under bright light conditions suggest that 8-inch bass can detect bluegills larger than 1.6" across the full width of an open area in the 2S habitat type. Therefore, maximum $E(E)$ s will be achieved by an 8-inch bass if it positions itself in the middle of an open strip so that it can watch both edges of vegetation simultaneously. However, 8-inch bass can only detect bluegills which are too large to consume (larger than 3.5") across the open width in the 1S habitat. Since they can not watch both edges at the same time, maximum $E(E)$ s are achieved by bass in the 1S habitat by remaining close to and watching one edge. This results in maximum $E(E)$ s

which are twice as large in the 2S habitat compared to the 1S (ratios of 2.0).

Under low light conditions, RDs of 8-inch bass are so reduced that they can not detect bluegills less than 4.6" in total length across the open water area in the 2S habitat. Since open water width has less effect on estimates of $E(E)$ s because bass can not watch two edges simultaneously in this case, edge effects are negligible and bass position and maximum $E(E)$ s are similar between the two habitats resulting in ratios close to 1.0. In fact, 8-inch bass in the 1S habitat type encountered slightly greater numbers of bluegills when bluegills remained close to an edge of vegetation, resulting in ratios less than 1.0. This is attributable to the fact that density of bluegills per unit area of edge is greater in the 1S than in the 2S habitat, since the latter has twice as much edge.

This same logic can be applied to results for 11-inch bass. However, since RDs of 11-inch bass to varying sizes of bluegills are significantly greater than those of 8-inch bass, effects of open strip width in a habitat are not as significant as for smaller bass regardless of light intensity. Thus, edge effects are less pronounced for 11-inch bass, as witnessed by lower ratios of $E(E)$ s between 2S and 1S habitats.

Further simulation runs were made to study effects of various spatial distributions of bluegills in open strips by relating distance bluegills would travel from an edge of vegetation to bluegill size. This allowed an analysis of different bluegill behaviors which incorporated their reaction to predation risk in open water areas of each habitat type. Because behavior was set for each distribution based on bluegill size, the only factor affecting numbers of bluegills encountered by bass in any given scenario was bass position. Therefore, maximum $E(E)$ s, position of a bass at which these occurred, and ratios between the two habitat types were estimated for each assumed bluegill behavior. Complete solutions for each scenario are

presented in graphical form in Smith (1993a; Appendix G, Figures G-1 through G-12).

Simulation results for 8-inch bass assuming either high or low light conditions and a spatial distribution of bluegills which increased monotonically to an asymptote were similar to those observed for the uniform distribution (Table 1). Maximum $E(E)$ s in the 2S habitat always occurred when a bass was 18" from an edge of vegetation. Position of a bass in the 1S habitat which maximized $E(E)$ s increased towards 18" as bluegills moved further into an open area. Also, ratios of $E(E)$ s between habitat types increased towards 2.0 as the maximum distance of bluegill travel was increased. These results contrast with those assuming either a sigmoid or exponential distribution described bluegill movement. Although bass position which maximized $E(E)$ s in the 2S habitat was similar for all three distributions used to predict bluegill movements as a function of their size into open water, maximum numbers of bluegills were encountered by 8-inch bass in the 1S habitat only when a bass remained close to an edge of vegetation. Finally, the trend in ratios was opposite that for the asymptotic bluegill behavior distribution, with ratios close to 2.0 when distance traveled by a 4.9-inch bluegill was 18" into open water, and either decreasing or remaining constant as bluegills moved further from an edge of vegetation.

Simulation results for 11-inch bass assuming high light intensity and either the asymptotic or sigmoid bluegill spatial distributions were consistent with those for the uniform distribution (Table 2). Maximum $E(E)$ s in the 2S habitat again always occurred when a bass was 18" from an edge of vegetation. In the 1S habitat type, position of a bass which maximized $E(E)$ s increased towards 18" with increasing bluegill movements. Also, ratios increased towards 2.0 as bluegills moved further from an edge. In contrast, results for the exponential distribution showed that maximum $E(E)$ s

always occurred when a bass was close to an edge of vegetation in the 1S habitat. The trend in ratios was also reversed, with ratios remaining constant at 1.9 as bluegill movements increased.

Under low light conditions, scenarios for 11-inch bass assuming either a monotonic-increase-to-an-asymptote or sigmoid distribution to describe bluegill behavior again gave results similar to the uniform distribution, with three exceptions. First, the sigmoid model predicted maximum encounter probabilities which were smaller than those observed for 11-inch bass assuming bright light conditions, which was opposite of the uniform and asymptotic dispersion simulations. Second, bass position in the 2S habitat was different, with maximum $E(E)$ s always occurring when a bass was 18" from an edge. Third, although $E(E)$ ratios increased as distance traveled by bluegills into open water increased, they were generally larger than those estimated for the uniform distribution. Results for the exponential distribution were very different when compared to results from the other three distributions. Although bass position which maximized $E(E)$ s in each habitat type was similar to those observed for the other bluegill behavior distributions, predicted maximum numbers of bluegills encountered were much smaller in low light than in high light conditions, which was opposite the trend observed under the uniform, asymptotic, and sigmoid distributions.

The similarity of results for the asymptotic, sigmoid, and exponential bluegill behavior distributions to specific portions of results for the uniform distribution is interesting. For example, results for the asymptotic distribution which allows even the smallest bluegills to move a considerable distance from an edge of vegetation are most similar to those for the uniform distribution when all sizes of bluegills move 18" or more into open water. Conversely, results for the exponential distribution are very consistent

with those for the uniform distribution when bluegills of all sizes are forced to remain close to vegetation. The sigmoid distribution is split between these two cases, with results for 8-inch bass similar to those for the asymptotic distribution and for 11-inch bass the exponential. This is caused by differences in both distances at which these sizes of bass react to varying sizes of bluegills and in sizes of bluegills which can be consumed by 8- and 11-inch bass. Thus, it is apparent that the model is not very sensitive to how bluegills react to predation risk in terms of whether or not distances traveled into open water are related to bluegill size. However, although the distributions used to describe bluegill behavior have very little effect on either bass position at which $E(E)$ s are maximized or ratios of $E(E)$ s between the two habitat types, there are significant differences between predicted maximum numbers of bluegills encountered for the different distributions.

Effects of width of open water between edges of vegetation on ability of 8- and 11-inch bass to encounter bluegills were analyzed by assuming open strips that were half and twice as wide as those used in field trials (Smith 1993b). In the first scenario, the 1S habitat was assumed to contain one strip which was 36" in width and the 2S habitat two open strips of 18" in width (small model). In the second scenario, the 1S habitat contained one 144" open strip and the 2S two 72" open strips (large model). Maximum $E(E)$ s, bass position at which these occurred, and $E(E)$ ratios were estimated for both the sigmoid and exponential bluegill behavior distributions. Complete solutions for each scenario are presented in graphical form in Smith (1993a; Appendix G, Figures G-13 through G-20 for the small model, and G-21 through G-28 for the large model). In general, observed relationships between bass size, light intensity, habitat type, and bluegill behavior distributions within small and large models were similar to the original results reported previously. However, there were

distinct similarities and differences between the small and original, and large and original, model results depending on bass size and light intensity.

Decreasing open strip widths by half had only slight effect on maximum $E(E)$ s for 8- and 11-inch bass under high light conditions when compared to the original model (Tables 3 and 4). Trends in bass position at which maximum $E(E)$ s were attained were identical to those for the original model. However, halving open widths did not reduce maximum $E(E)$ s for bass in the 2S habitat nearly as much as in the 1S, resulting in ratios that were much closer to 2.0 than in the original model. This result implies that, under bright light intensity, open strip widths used in field trials (Smith 1993b) and original simulations were close to optimal in terms of altering the predator-prey interaction between bass and bluegills by manipulating edge.

Under low light conditions, reducing open strip widths by half had significant effects on both position of 8-inch bass in the 2S habitat at which maximum $E(E)$ s were observed and $E(E)$ ratios. Bass always remained in the middle of an open strip in the 2S habitat in the small model as opposed to moving out from an edge as bluegills moved in the original model. Trends in bass behavior in the 1S habitat were similar for the two models for both bluegill behavior distributions simulated. This resulted in ratios of maximum $E(E)$ s between habitat types which were much larger than in the original model and never went below 1.0 for either distribution used to simulate bluegill behavior. Distances at which 8-inch bass react to bluegills of varying sizes are greatly reduced under low light conditions. However, reducing open strip width in the 2S habitat from 36" to 18" created a narrow enough area to allow 8-inch bass to watch both edges of vegetation simultaneously and thus detect bluegills anywhere in an open water area. Conversely, open strip width in the 1S habitat was still too large to afford

8-inch bass an opportunity to watch and detect bluegills on both edges at the same time.

Results for 11-inch bass under low light conditions were not as dramatic as for smaller bass, since open strip widths in the original model were close to optimal for 11-inch bass in low light. Trends in bass position for each habitat type at which maximum $E(E)$ s were attained were identical to those observed in simulation results for the original model. However, effects of edge and open water widths were somewhat stronger in the small model, resulting in ratios of $E(E)$ s between habitats which were slightly improved (i.e., closer to 2.0).

A doubling of open strip widths in each habitat produced dramatic differences in results for 8-inch bass under bright light conditions, and 11-inch bass under low light conditions (Tables 5 and 6). Edge effects observed in results for the original model, which gave bass in the 2S habitat an advantage over bass in the 1S habitat resulting in ratios close to 2.0, were nullified by the wide open area in the 2S habitat simulated in the large model. Although position of bass at which maximum $E(E)$ s were achieved were not different between the two models, maximum $E(E)$ s were greatly reduced for bass in the 2S habitat since they could no longer watch both edges simultaneously. Thus, ratios of $E(E)$ s between habitat types were close to 1.0, implying that effects of edge were no longer important in these cases.

Simulation results from the large model for 8-inch bass under low light conditions were not significantly different than those observed in the original model. This was expected since results from the original model had already suggested that increasing amounts of edge did not increase maximum $E(E)$ s in the 2S habitat compared to the 1S. This is attributable to the fact that RDs of 8-inch bass were too small under low light conditions to allow bass to watch both edges

at the same time, even in the 2S habitat, in the original model. Therefore, widening open water areas between refuges will give the same results, with $E(E)$ ratios which are still very close to 1.0, thus negating any effects of edge.

Effects of widening open areas on results for 11-inch bass assuming bright light conditions were only slightly different from those observed for this case in the original model. Although $E(E)$ ratios were somewhat reduced compared to those in the original model, they were still well above 1.0 implying that effect of doubling open widths was not as significant for 11-inch bass as it was for 8-inch bass under bright light conditions. Since RDs of 11-inch bass to bluegills are much greater than for 8-inch bass, larger bass could still detect to some extent bluegills on both edges of vegetation in the 2S habitat even though the distance between edges had been doubled. Also, 11-inch bass can consume much larger bluegills than can 8-inch bass, and larger bluegills can be detected at greater distance by bass. Thus, effects of edge were not completely overwhelmed by doubling open area widths in this scenario.

General observations of the magnitude of numbers of bluegills encountered within and between bass sizes and light conditions were very consistent regardless of habitat model (small, original, or large) employed in a simulation. Eight-inch bass always had greater $E(E)$ s in high light intensity conditions than they did at low light, regardless of the bluegill behavior distribution assumed to be operative. However, 11-inch bass only had higher encounter probabilities in bright light if bluegill behavior was assumed to function in a sigmoid or exponential fashion. The reverse was true if either the uniform or asymptotic distributions were employed to describe prey behavior.

Under high light intensity, 8-inch bass had larger $E(E)$ s than 11-inch bass if bluegill behavior was regulated by either the uniform or asymptotic distributions. The opposite was

true for the sigmoid and exponential distributions. However, 11-inch bass always had greater probabilities of encounter in low light situations for all distributions used to simulate bluegill behavior.

Discussion

Results from the encounter model suggested that edge effects would double maximum numbers of bluegills encountered by 8- and 11-inch bass in the 2S habitat compared to the 1S, under certain conditions of light intensity, assumed bluegill behavior, and bass position in an open water area between vegetated plots. Although this supports my original hypothesis that a two-fold increase in amount of edge would double predation rates of bass feeding on bluegills, empirical evidence from field trials reported in Smith (1993b) showed a much stronger effect of edge on predation rates, which averaged 4.4 times greater in the 2S habitat than in the 1S for both sizes of bass combined. However, maximum numbers of bluegills encountered by 8- and 11-inch bass and ratios of maximum $E(E)$ s between habitat types were estimated in the model under an assumption that spatial distributions of bluegills in both habitats were identical in a given scenario, while bass would move to positions in open water areas in each habitat which maximized $E(E)$. Yet, it is highly likely that reactions of bluegills to predation risk in the 2S habitat would not be as strong as in the 1S, and bluegills of all sizes would travel further into open water in the 2S habitat. Model simulations further supported this idea since estimated numbers of bluegills encountered and resulting ratios between habitats were not as sensitive to assumed bass behavior (i.e., distance a bass positioned itself from an edge) as they were to assumed bluegill behaviors.

Predator and prey behaviors are not independent of each other in nature, and

position from an edge chosen by bass to maximize $E(E)$ is most likely dictated by bluegill behavior. Further, effects of both light intensity, which changes reaction distances of bass and bluegills to each other, and widths of open water areas between refuges where predatory interactions occur will regulate position used by bass to maximize encounters with bluegills. In general, model results supported this contention, demonstrating that bass would maximize $E(E)$ by stationing themselves a specified distance from an edge. The best location depended on distances traveled by bluegills into an open water area, bass size, and ambient light levels.

Results of simulations using behavioral distributions which curtailed movement of bluegills into open water (i.e., sigmoid, exponential, or truncated uniform) showed that numbers of bluegills encountered by both 8- and 11-inch bass were greater in daylight simulation than in twilight. This implies that Howick and O'Brien's (1983) small bass category would include at least 11-inch and smaller bass. If their conclusion is appropriate and small bass do actively forage during daylight, then the majority of predation mortality suffered by bluegills probably occurs during this period. Hence, model results for low light intensity may not be as important as for high light conditions given sizes of bass used in my study. This premise is further supported by the fact that model predictions of maximum $E(E)$ ratios in low light were very close to 1.0 for both sizes of bass, indicating amount of edge in the two habitats had no effect on numbers of bluegills encountered in either habitat. However, ratios were near 2.0 in simulations assuming bright light, which suggests that doubling edge increased $E(E)$ s in the 2S habitat two-fold compared to the 1S.

Laboratory experiments have shown that during bright light conditions, bluegills can see large bass long before bass see them (Howick and O'Brien 1983). Bass out in

open water would have a high profile, which would effectively alter bluegills' reaction to predation risk, resulting in bluegills remaining close to refuges (Werner et al. 1983). Thus, large bass should stay near vegetation and ambush bluegills (Savino and Stein 1989a), especially given advantages associated with both physical shading (Helfman 1979) and background camouflaging (Endler 1986). However, it would be more profitable for small bass to actively search for bluegills during daylight. This is attributable to the fact that only the smallest bluegills can see smaller bass first, and many bluegills encountered would be too large for these bass to consume. Conversely, all sizes of bass would have an advantage in low light. Since their association with edge would be less important because they can see most sizes of bluegills first, they could cruise open water areas more effectively.

Although the model was not capable of determining actual foraging strategies of bass under differing conditions of light intensity and bluegill behavior, simulation results did demonstrate trends in bass behavior which were consistent with empirical evidence. Of significant interest are model estimates of probable positions of bass which maximized $E(E)$ s in the two habitats under different light conditions. Assuming that bluegills remained near vegetation (i.e., bluegill behavior is described by a sigmoid or exponential distribution), the difference in width of open water areas between 2S and 1S habitat types did influence bass behavior. Model results suggest that both sizes of bass would be out in the middle of an open strip in the 2S habitat but near an edge of vegetation in the 1S during bright light conditions. During twilight situations, 8-inch bass would be near edges of vegetation in both habitats, but 11-inch bass would still exhibit behaviors similar to those predicted for this size of bass under bright light conditions. These patterns are significant and point out the importance of width of open water areas and light

intensity to estimates of reaction distances and thus $E(E)$ s. For example, reaction distances of 8- and 11-inch bass to various sizes of bluegills are, on average, large enough to span an open area in the 2S habitat if a bass is in the middle of an open strip during daylight. Thus, maximum $E(E)$ s are attained if a bass cruises the middle of an open strip since it can watch both edges of vegetation simultaneously and detect bluegills moving into open water from either edge. This is true even if bluegill behavior is simulated by an exponential distribution, which assumes that predation risk is high and thus bluegills of all sizes are forced to remain relatively close to edges of vegetation. In the 1S habitat, reaction distances are small relative to open strip width and thus both sizes of bass would maximize their encounter rates by remaining close to one edge of vegetation. However, in low light conditions, average reaction distances of 8-inch bass are greatly reduced and bass would do best by remaining near vegetation in both habitat types. This eliminates any effect of edge and ratios of 1.0 were in fact observed in this scenario. The reduction in 11-inch bass reaction distances in low light is not as great as for smaller bass. Therefore, position which maximizes $E(E)$ for 11-inch bass would still be in the middle of an open water area in the 2S and near an edge of vegetation in the 1S habitat, as for bright light conditions.

Simulation results were dramatically affected by assumed bluegill behaviors, in terms of their reaction to predation risk, which was modeled by using different distributions to describe distances individuals were willing to travel from an edge of vegetation as a function of bluegill size. Simulation of bluegill behaviors using these distributions had significant impacts on the ability of bass to encounter bluegills. Both magnitudes and trends observed for maximum $E(E)$ s varied within and between habitat types and light intensities for different bluegill behavioral responses. However, it

was not possible to differentiate between results for certain distributions that related distance traveled by bluegills into open water to bluegill size, and results for portions of the uniform distribution which allowed all bluegills to travel a specific distance regardless of their size. For example, maximum edge effects were predicted for both sizes of bass under high light intensity with $E(E)$ ratios of 2.0 if bluegill movement was severely restricted assuming a uniform distribution, or if bluegill behavior was simulated by an exponential, and in some instances, a sigmoid distribution. Conversely, minimal edge effects were predicted by these same distributions when light intensity was low, resulting in ratios at or even below 1.0.

Crowder and Cooper (1979, in particular see Figure 1D) hypothesized that prey association with structure should increase sigmoidally with prey vulnerability. Although I tested this distribution and model results were consistent with those from my field experiment (Smith 1993b), simulations employing an exponential distribution, or a uniform distribution with minimal bluegill movement into open water, also produced similar outcomes. However, model estimates of maximum $E(E)$ s were greater overall assuming bluegill behavior was described by a sigmoid distribution than for the other two distributions. This lack of ability in the model to differentiate between bluegill behavior distributions arises because the model was only sensitive to large perturbations in bluegill movements. For example, the uniform distribution assumes no relationship between bluegill size and their association with edge. If bluegills of all sizes are allowed to go only a short, but equivalent, distance from a refuge into open water, then the uniform distribution gives results similar to those assuming an exponential distribution is used to describe bluegill behavior. Although the latter distribution effectively relates distance traveled from an edge to bluegill size, it generally predicts very limited

movement for all but the largest bluegills. Since both of these distributions generate results which are consistent with field observations of Werner and Hall (1988), it is likely that Crowder and Cooper's (1979) proposed sigmoid relationship could also be fit appropriately. The model is not sensitive enough to determine the exact nature of the relationship between bluegill size and reaction to predation risk on a short term basis, but does make clear that only those distributions which curtail movement of bluegills into open water areas give results consistent with empirical data from my field experiment (Smith 1993b). Thus, any of these distributions could explain bluegill behavior, implying that size of an individual bluegill may not affect its reaction to predation risk on a day-to-day basis once it has been confined to vegetation by presence of bass.

The possible insignificance of a relationship between bluegill size and their reaction to predation risk on a daily basis, and thus short term movements of bluegills, contrasts with marked shifts in habitat use observed for bluegills during their ontogeny (Werner et al. 1983). Model results do demonstrate, however, that operative mechanisms responsible for ontogenetic shifts in habitat use by bluegills may not be nearly as strong or important in regulating daily movements of small bluegills. Butler (1988) had similar conclusions in regard to bluegill behavior after making in situ observations of bass and bluegills during daylight hours in a natural lake. He found that habitat complexity significantly influenced bluegill behavior and abundance, while presence of bass seemed to have very little effect on choice of habitats or social behavior exhibited by bluegills of any size. Regardless of the exact nature of behavioral responses by bluegills, if a close association of bluegills with vegetation is assumed, then the encounter model does predict both

appropriate ratios between habitats and reasonable behavioral responses by bass.

Results of simulations in which open strip areas were halved and doubled in the two habitat types further support the hypothesis that edge effects can be explained by changes in numbers of bluegills encountered by bass in the two habitat types. If bluegills are assumed to associate closely with structure, and encounter depends on average reaction distances of bass to various sizes of bluegills present, then halving an open strip width should have minimal effect on maximum $E(E)$ ratios. Conversely, doubling open widths should result in ratios close to 1.0, since bass can no longer see both edges of vegetation simultaneously. As expected, halving open widths had very little effect on predicted ratios of maximum $E(E)$ s between the two habitat types for either size of bass in bright light simulations. However, $E(E)$ ratios increased for both bass sizes under low light conditions when open strips were half as wide as in the original simulation. Thus, cutting open strip widths in half gave bass an advantage in the 2S habitat since they could now detect bluegills moving into open water off either edge concurrently, even though distances at which bass react to bluegills are greatly reduced under conditions of low light. On the other hand, doubling open strip widths significantly reduced predicted ratios very close to 1.0 for 8-inch bass under both high and low light conditions, and for 11-inch bass assuming low light intensity. However, ratios were equivalent (and close to 2.0) between the original model results and those predicted for 11-inch bass under high light intensity when open strip widths were doubled.

Effects of open water width on ability of bass to encounter bluegills also demonstrate that geometrical configurations which result from creating edge will have important consequences on the predator-prey interaction. For example, if edge was created such that one habitat had 60 contiguous feet

of edge versus 30 contiguous feet in another habitat, bass could not search two edges at one time. Also, it would take bass longer to search the 60-foot edge compared to the 30-foot, and bluegill density (number per foot of edge) would be less in the former habitat. In this case, encounters of bluegills by bass would probably be less in the habitat with more edge, which is opposite of my field (Smith 1993b) and modeling results. Thus, geometry must be considered when creating edge and the best method appears to be removal of rectangular strips of vegetation, resulting in a configuration of vegetated and open areas which allow bass to detect bluegills on two edges simultaneously.

Computer simulation results also offer an explanation for differences between ratios of predation rates in the two habitat types for 8- and 11-inch bass in my field experiment (Smith 1993b). I observed a higher ratio (5.0) for smaller bass than I did for larger bass (3.4). It appears that open strip widths I chose for field trials were close to those which would maximize both numbers of bluegills encountered by 8-inch bass in the 2S habitat type and the ratio between habitats under bright light conditions. However, slightly wider open water areas could have produced more significant effects of edge for 11-inch bass as witnessed by simulation results for doubling open strip widths. This implies that a significant portion of the potential reaction volume of 11-inch bass was truncated by vegetation in the 2S habitat type because of the relatively narrow open strip in this habitat. Thus, 11-inch bass could not perform as well in the 2S habitat open water areas as 8-inch bass, relative to performances of their respective counterparts in the 1S open strip.

Unknown effects of increasing edge on both bass and bluegill behavior mandates a general approach to simulation of these components. A consequence of the lack of constraints in the model is that it can predict a tremendous number of outcomes, many of

which do not fit known theory. Yet, the point of modeling is to determine what factors are significant in an interaction being simulated and if any of the specific hypotheses under analysis give plausible explanations for outcomes predicted by the model. Thus, important simulation results are those which reflect empirical observations of behavioral responses of bass and bluegill to structure.

The prevailing assumption throughout this discussion has been that reaction of bluegills to predation risk was equivalent in the two habitat types. This implies that bluegill behavior is independent of both width of open water areas between refuges and perceived density of bass in the immediate locale. Yet, either factor could invoke significant changes in bluegill behavior which would have important consequences on the outcome of the predator-prey interaction (Werner and Hall 1988). In Smith (1993b), I discussed possible ramifications of both the distance between refuges and bass density on behavioral responses of bluegills in the two habitat types. First, bluegills of any size might be more willingly to come out into an open water area, and traverse more frequently between refuges, if the distance between refuges was small. Second, I observed during field trials that bass in the 2S habitat were seldom found together since each occupied a separate open strip, whereas both bass occupied the single open water area in the 1S habitat along opposite edges of vegetation. This may result in bluegills encountering bass more frequently in the 1S habitat type. The conclusion, then, is that either of these possibilities could decrease frequency of movements into open water, and/or distances bluegills were willing to travel into open water, in the 1S habitat relative to the 2S.

Using the above assumption, the model does predict ratios of maximum $E(E)$ s which are consistent with results from the field experiment. For example, first assume that

the largest bluegill (4.9") would move half as far from an edge of vegetation in the 1S habitat type as the same sized fish in the 2S habitat. Second, assume that the behavioral response of bluegills is described by a sigmoid distribution relating bluegill size to distance an individual would move from an edge of vegetation (Crowder and Cooper 1979). The second assumption then causes a minimal effect of the first on bluegill movement. Although the largest sized bluegill doubles its distance from an edge in the 2S compared to the 1S habitat under these assumptions, differences between distances from an edge in the two habitat types will be progressively reduced with decreasing bluegill size. Distances will be almost equivalent in the two habitats for smaller individuals. If ratios of maximum $E(E)$ s between habitat types are calculated under these assumptions, it becomes very evident that even minor changes in bluegill behavior can have significant impacts on the ability of bass to encounter bluegills in the two habitat types. Predicted ratios range from 4.0 for 8-inch bass under high light conditions to 2.1 under low light intensity (using results from Table 1). For 11-inch bass, ratios are 3.2 and 2.8 for high and low light intensities, respectively (using results from Table 2). These results are very close to what I observed for magnitudes of differences between predation rates in 2S and 1S habitats for 8- and 11-inch bass in my field experiment (Smith 1993b). Thus, it is likely that bluegills did respond differently in the two habitats to predation risk, either because of differences in frequency with which bass were encountered or distance between vegetated plots in 2S and 1S enclosures.

The above example demonstrates that the ability of bass to encounter bluegills is extremely sensitive to subtle changes in reactions of bluegills to possible predation risk in the two habitat types. It also reinforces the idea that effects of edge are strongly dictated by changes in behavioral

response of bluegills to their surroundings, along with interactions between bass reaction distances to bluegills, open water strip width, and light intensity. This conclusion is not surprising given empirical evidence to date on ontogenetic shifts in habitat use. However, it is the first example to demonstrate that reactions to predation risk on a daily time scale can result in behavioral responses by bluegills which may be extremely difficult to measure, and that these very finite changes can have significant effects on their ability to avoid detection and capture. Such a phenomenon has important consequences not only for a successful use of edge to alter predator-prey interactions, but also on the magnitude of impacts that may be achieved. Thus, more research will be required to determine both the distribution which describes behavioral responses of bluegills to predation risk in terms of bluegill size and their association with structure (Crowder and Cooper 1979), and mediating effects of width of open water areas between refuges on bluegill behavior. In Smith (1993b), I reported that one of the five most important factors in determining an appropriate configuration for creating edge was width of open water areas between macrophyte beds. Model results further emphasize this fact and the implication is clear: an algorithm to determine suitable open water widths is complex and will need to incorporate knowledge of bass reaction distances to bluegills, size structure of bass and bluegill populations, bass foraging tactics including temporal and spatial aspects of preferred foraging strategies, and bluegill behavioral responses to their environment.

Modeling can be a very useful tool to predict effects of changes in various factors on a system, to determine sensitivity of system performance to specific factors, or to determine plausible explanations for, and acceptance or rejection of, alternate hypotheses about operative mechanisms controlling a system. Since many different

ideas can be tested quickly, models can be abused through choices of inappropriate scenarios which are not consistent with known attributes of a system, or by reporting output which has no intrinsic linkage to mechanisms occurring within a system. However, if models are used judiciously, they can elucidate unknown, and often unanticipated and surprising, relationships between important mechanisms in a system which conform to known theory. An obvious benefit, then, is a greater understanding and wiser use of these components in management policies implemented to maintain and enhance system performance.

Through the modeling exercise reported herein, I have demonstrated some important factors which determine effects of edge on a predator-prey interaction between bass and bluegills. These results have inherent meaning in this interaction, conform to known ecological principles which are important in describing the system, and lead to plausible explanations for results I obtained in my field experiment (Smith 1993b). These results further demonstrate that the main effect of edge is likely related to changes in number of bluegills encountered by bass. Important components which determine success of bass in relation to edge consist of a complex set of interactions between behavioral responses of bluegills to their surroundings, width of open water areas between refuges, and average reaction distances of bass to various sizes of bluegills. The last factor is additionally complicated by effects of light intensity on the ability of bass and bluegills to see each other, which in turn affects when bass of certain sizes would be most efficient in actively searching for bluegills. Lastly, model results support the premise that arbitrary destruction of macrophyte beds will have profound impacts on the structure of fish communities in natural lakes. Thus, such actions should be curtailed in favor of policies which determine approaches to vegetation management which

benefit both the aquatic life inhabiting an ecosystem and recreational users of public waters.

Acknowledgements

I wish to acknowledge those individuals who, through long (and in their minds probably often trying) discussions, helped me to not only formulate this project but to critically review my methods and techniques. Special thanks to Drs. James S. Diana, M. Anthony Schork, and Gary Belovsky of The University of Michigan, and Dr. W. Carl Latta, Dr. Richard D. Clark, Jr., James C. Schneider, James R. Ryckman, Dr. Paul W. Seelbach, Roger N. Lockwood, James

"Gappy" Gapczynski, and the late Percy W. Laarman of the Michigan Department of Natural Resources, Institute for Fisheries Research. Drs. Diana, Schork, Clark, and Latta, and Dr. James E. Breck also of the Institute, critically reviewed early drafts of this paper. In particular, I would like to credit Jim Breck for his assistance on the construction of the model. This project was conducted as part of my doctoral studies at The University of Michigan, School of Natural Resources and Environment, Ann Arbor, Michigan. Special thanks to the Michigan Department of Natural Resources who supported me and this study through a student fellowship, funded by a grant from Federal Aid in Sport Fish Restoration (Project F-35-R).

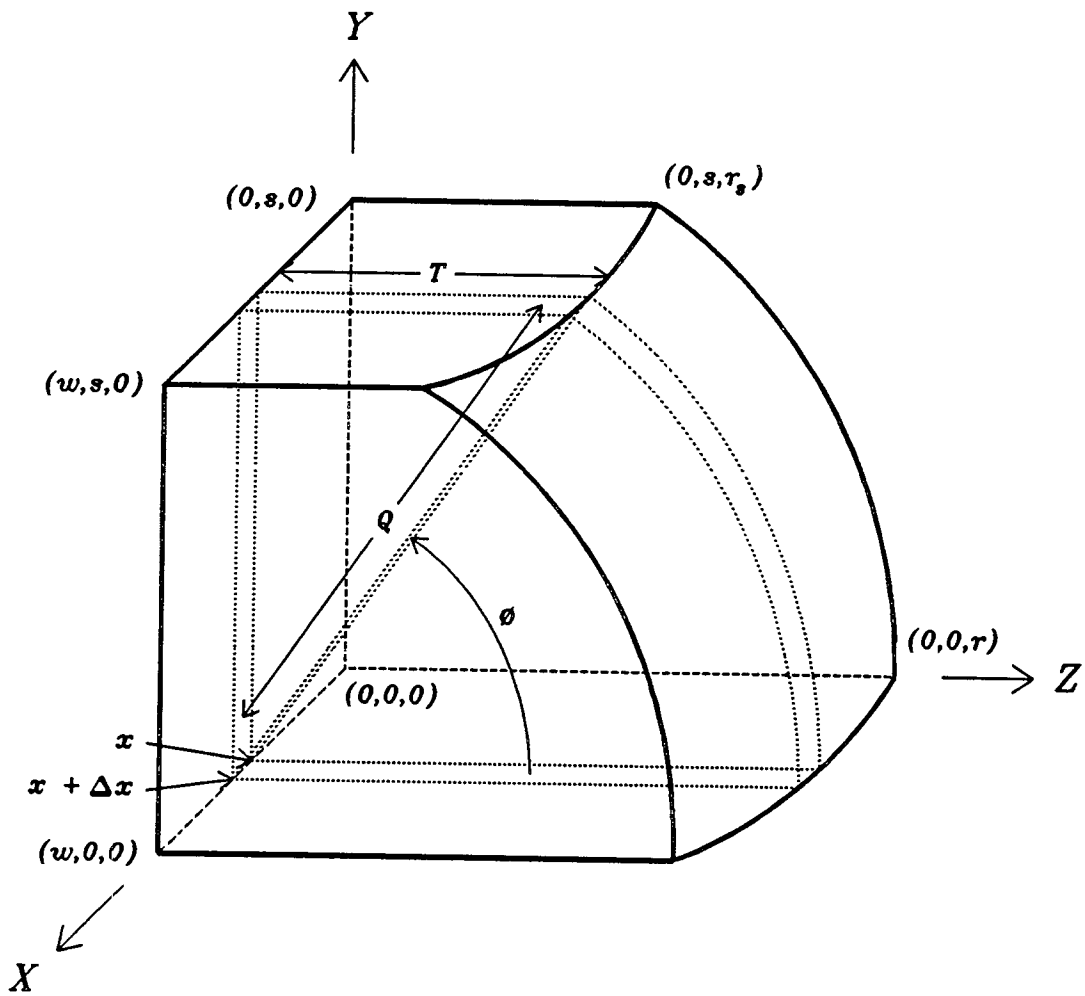

Figure 1.—Representation of the reaction volume (right side only) for largemouth bass, showing possible truncation by weed edge (side plane parallel to the Y-Z axes) and water surface (top plane parallel to the X-Z axes). The bass is parallel to the Z-axis, with the origin $(0, 0, 0)$ centered between its eyes.

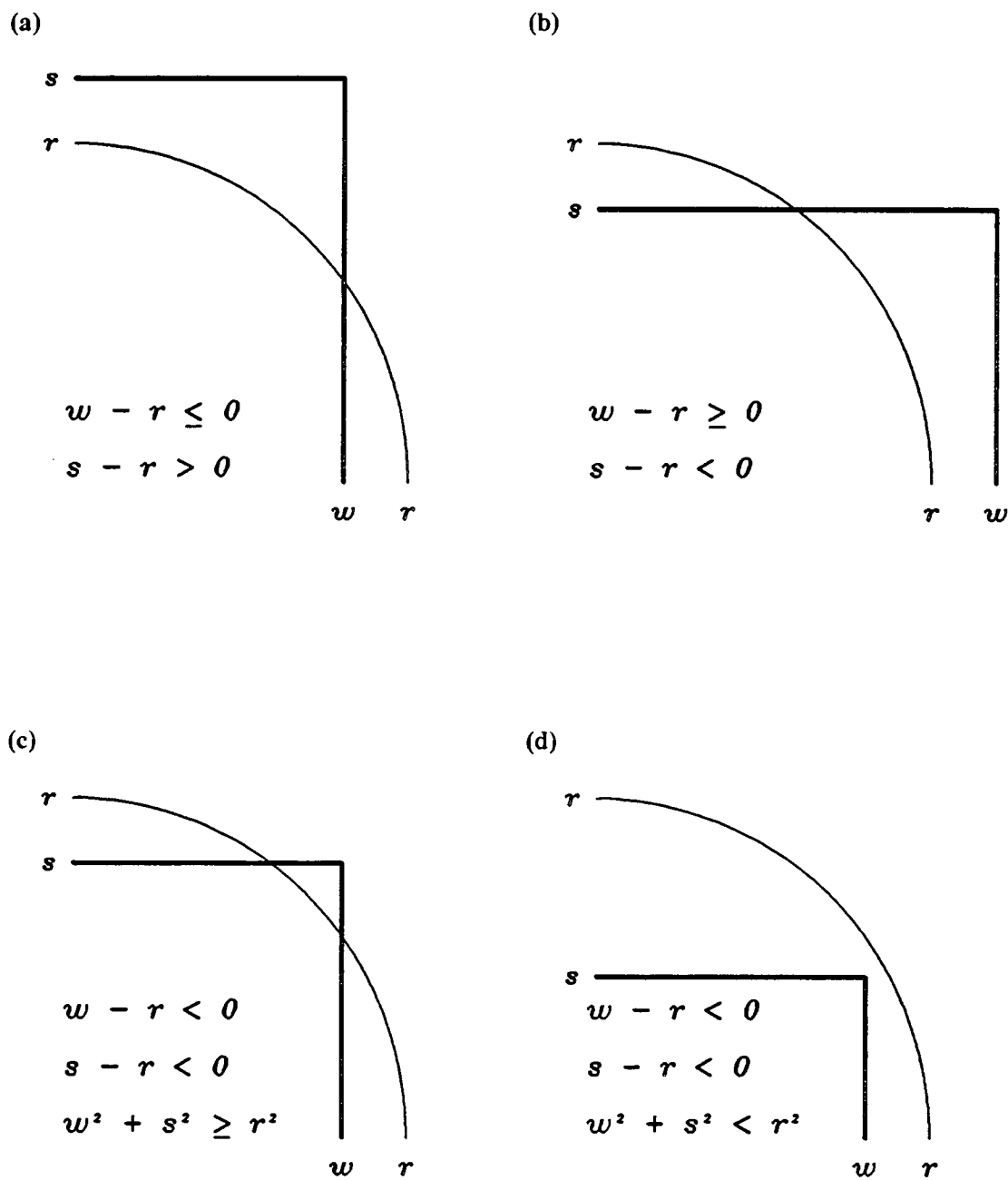

Figure 2.—Four possible cases of reaction volume truncation (X - Y axes view from Figure 1): (a) weed edge truncation; (b) water surface truncation; (c) partial weed edge and water surface truncation; and (d) complete weed edge and water surface truncation.

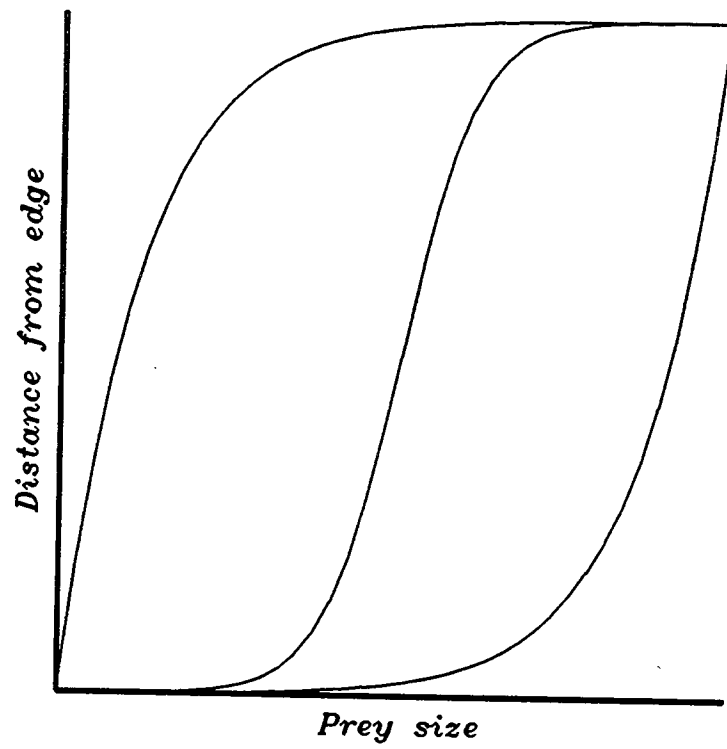

Figure 3.—Hypothetical distributions used to simulate prey behavior, described by distance moved from an edge of a refuge as a function of prey size.

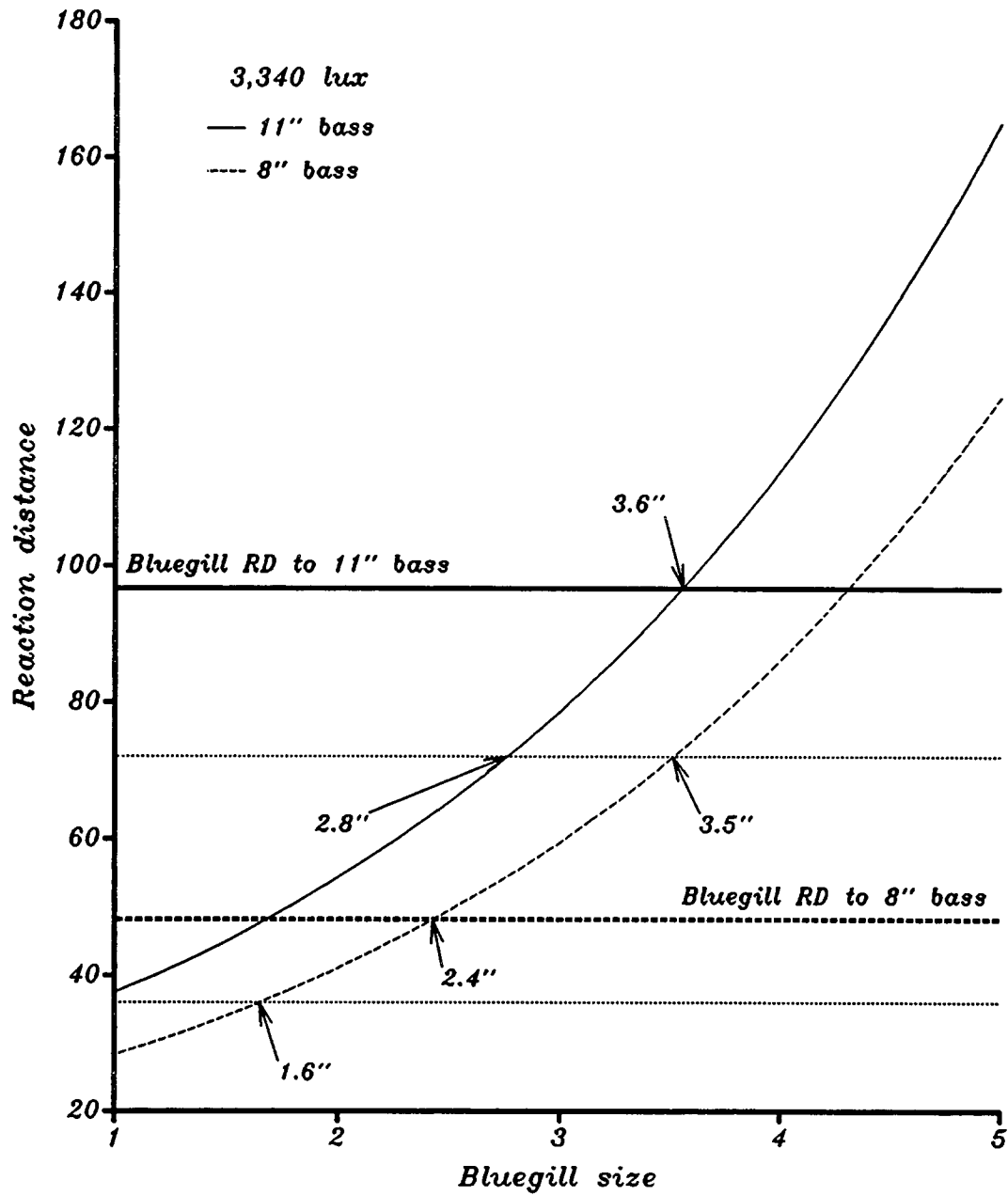

Figure 4.—Reaction distance (inches) of 8- and 11-inch bass to various sizes of bluegills (inches), and bluegills to these sizes of bass, at high light intensity. Dotted lines represent widths of open water areas in 2S (36") and 1S (72") habitat types.

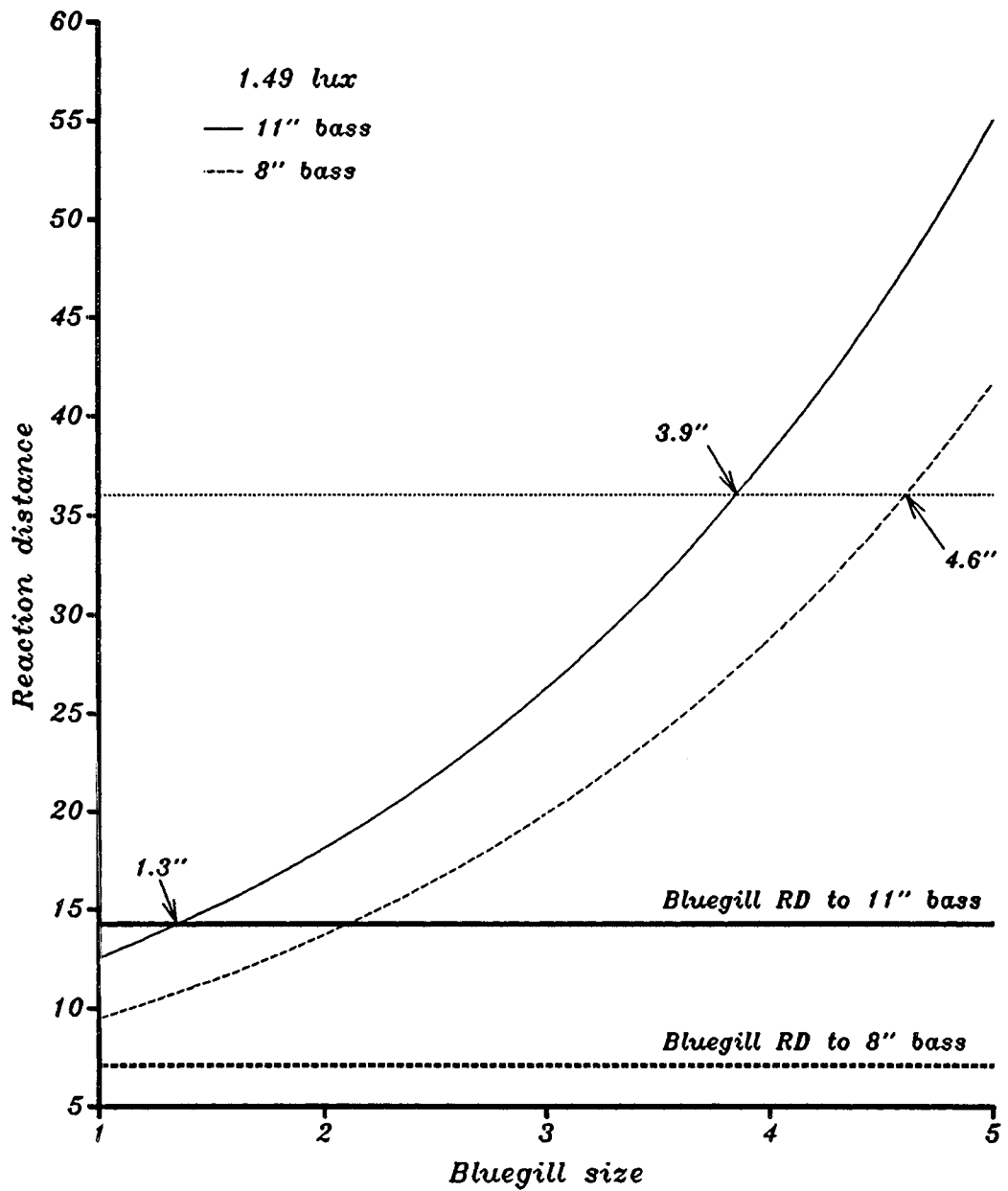

Figure 5.—Reaction distance (inches) of 8- and 11-inch bass to various sizes of bluegills (inches), and bluegills to these sizes of bass, at low light intensity. The dotted line represents width of an open water area in the 2S (36") habitat type.

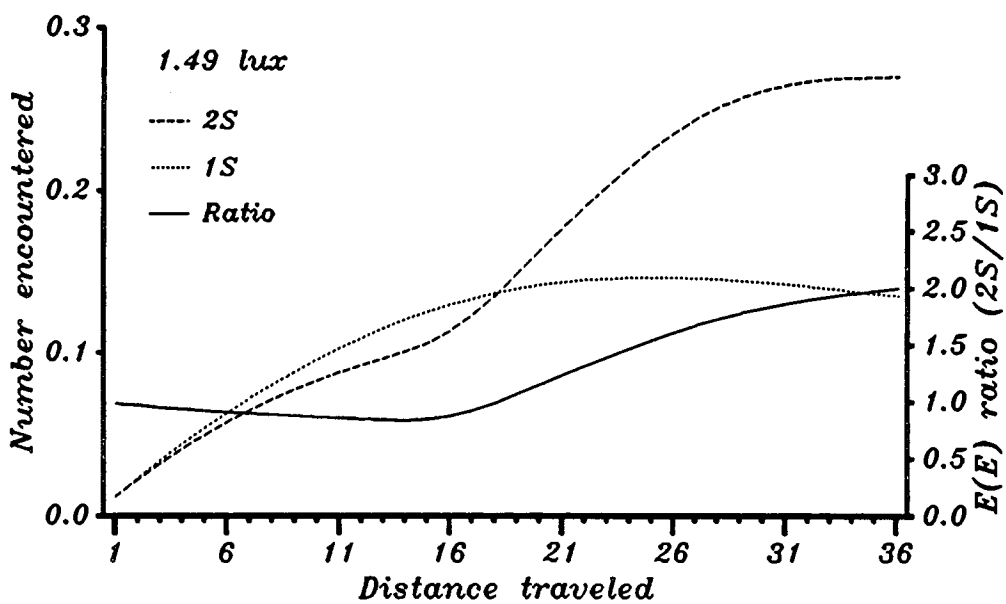
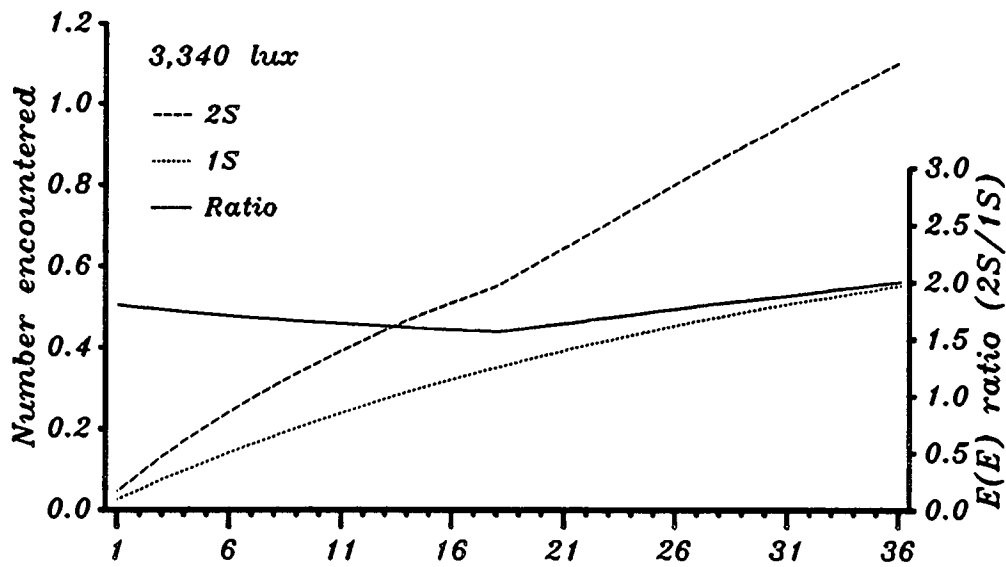

Figure 6.—Maximum number of bluegills encountered ($E(E) \times 1,000$) for 8-inch bass at high and low light intensities in 2S and 1S habitat types, and ratios of maximum $E(E)$ s (2S/1S), assuming distance traveled (inches) from an edge by bluegills increases equally for all sizes of bluegills (uniform distribution). Open water areas are 36" wide in the 2S habitat and 72" wide in the 1S habitat.

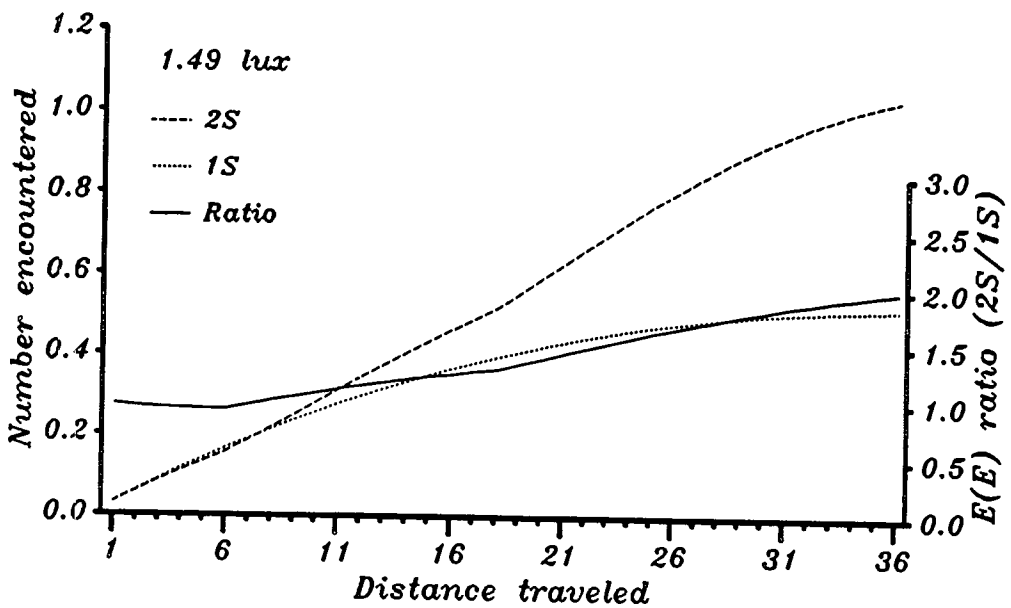
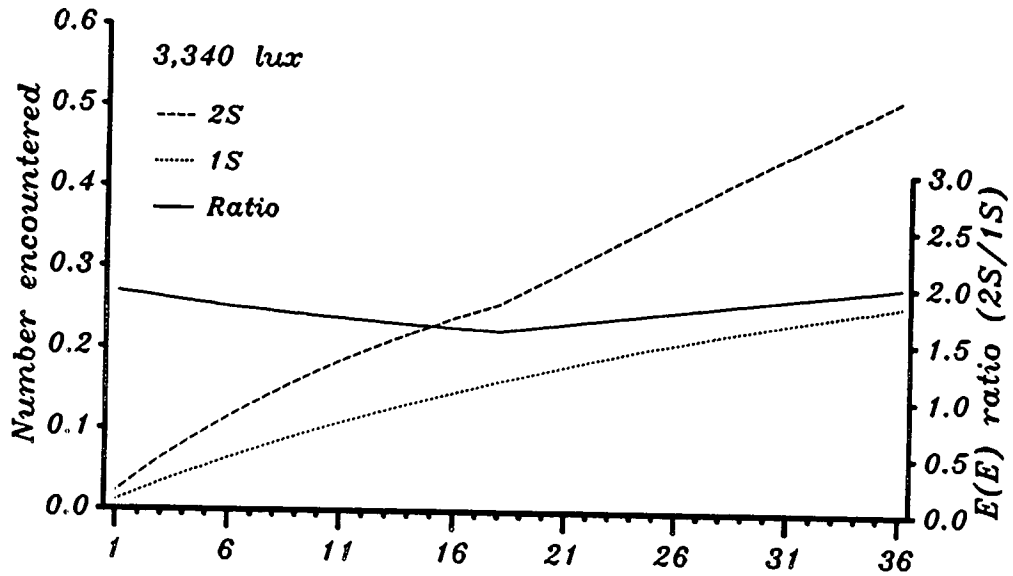

Figure 7.—Maximum number of bluegills encountered ($E(E) \times 1,000$) for 11-inch bass at high and low light intensities in 2S and 1S habitat types, and ratios of maximum $E(E)$ s (2S/1S), assuming distance traveled (inches) from an edge by bluegills increases equally for all sizes of bluegills (uniform distribution). Open water areas are 36" wide in the 2S habitat and 72" wide in the 1S habitat.

Table 1.—Maximum number of bluegills encountered ($E(E) \times 1,000$) and position of 8-inch bass at high and low light intensity in 2S and 1S habitat types, and ratios of maximum $E(E)$ s (2S/1S), assuming three distributions to describe different bluegill behaviors. Open water areas are 36" wide in the 2S habitat and 72" wide in the 1S habitat.

Bluegill distribution	Distance traveled ¹	2S habitat		1S habitat		Ratio (2S/1S)
		Maximum $E(E)$	Bass position ²	Maximum $E(E)$	Bass position ²	
High light intensity (3,340 lux)						
Asymptotic ³	18	0.5389	18	0.3430	9	1.6
	36	1.0662	18	0.5407	17	2.0
Sigmoid	18	0.1149	18	0.0649	1	1.8
	36	0.2570	18	0.1515	3	1.7
Exponential	18	0.0069	18	0.0038	0	1.8
	36	0.0137	18	0.0075	0	1.8
Low light intensity (1.49 lux)						
Asymptotic ³	18	0.1052	10	0.1192	7	0.9
	36	0.2452	18	0.1321	14	1.9
Sigmoid	18	0.0100	1	0.0104	1	1.0
	36	0.0221	3	0.0242	3	0.9
Exponential	18	0.0008	0	0.0008	0	1.0
	36	0.0016	0	0.0016	0	1.0

¹Maximum distance traveled (inches) from an edge of vegetation by the largest-sized bluegill (4.9").

²Distance (inches) of a bass from an edge of vegetation at which maximum $E(E)$ s were estimated.

³Distribution describing bluegill behavior in terms of a monotonic-increase-to-an-asymptote (Figure 3).

Table 2.—Maximum number of bluegills encountered ($E(E) \times 1,000$) and position of 11-inch bass at high and low light intensity in 2S and 1S habitat types, and ratios of maximum $E(E)$ s (2S/1S), assuming three distributions to describe different bluegill behaviors. Open water areas are 36" wide in the 2S habitat and 72" wide in the 1S habitat.

Bluegill distribution	Distance traveled ¹	2S habitat		1S habitat		Ratio (2S/1S)
		Maximum $E(E)$	Bass position ²	Maximum $E(E)$	Bass position ²	
High light intensity (3,340 lux)						
Asymptotic ³	18	0.2566	18	0.1610	9	1.6
	36	0.5125	18	0.2566	18	2.0
Sigmoid	18	0.2494	18	0.1555	9	1.6
	36	0.4972	18	0.2520	17	2.0
Exponential	18	0.0290	18	0.0151	1	1.9
	36	0.0555	18	0.0295	1	1.9
Low light intensity (1.49 lux)						
Asymptotic ³	18	0.4767	18	0.3760	8	1.3
	36	0.9986	18	0.5159	16	1.9
Sigmoid	18	0.1774	18	0.1351	5	1.3
	36	0.3848	18	0.2308	10	1.7
Exponential	18	0.0109	18	0.0092	0	1.2
	36	0.0217	18	0.0182	1	1.2

¹Maximum distance traveled (inches) from an edge of vegetation by the largest-sized bluegill (4.9").

²Distance (inches) of a bass from an edge of vegetation at which maximum $E(E)$ s were estimated.

³Distribution describing bluegill behavior in terms of a monotonic-increase-to-an-asymptote (Figure 3).

Table 3.—Maximum number of bluegills encountered ($E(E) \times 1,000$) and position of 8-inch bass at high and low light intensity in 2S and 1S habitat types, and ratios of maximum $E(E)$ s (2S/1S), assuming two distributions to describe different bluegill behaviors. Open water areas are 18" wide in the 2S habitat and 36" wide in the 1S habitat.

Bluegill distribution	Distance traveled ¹	2S habitat		1S habitat		Ratio (2S/1S)
		Maximum $E(E)$	Bass position ²	Maximum $E(E)$	Bass position ²	
High light intensity (3,340 lux)						
Sigmoid	18	0.0937	9	0.0493	1	1.9
	36	0.2134	9	0.1170	3	1.8
Exponential	18	0.0055	9	0.0028	0	2.0
	36	0.0110	9	0.0057	0	2.0
Low light intensity (1.49 lux)						
Sigmoid	18	0.0118	9	0.0079	1	1.5
	36	0.0295	9	0.0186	3	1.6
Exponential	18	0.0008	9	0.0006	0	1.3
	36	0.0016	9	0.0012	0	1.4

¹Maximum distance traveled (inches) from an edge of vegetation by the largest-sized bluegill (4.9").

²Distance (inches) of a bass from an edge of vegetation at which maximum $E(E)$ s were estimated.

Table 4.—Maximum number of bluegills encountered ($E(E) \times 1,000$) and position of 11-inch bass at high and low light intensity in 2S and 1S habitat types, and ratios of maximum $E(E)$ s (2S/1S), assuming two distributions to describe different bluegill behaviors. Open water areas are 18" wide in the 2S habitat and 36" wide in the 1S habitat.

Bluegill distribution	Distance traveled ¹	2S habitat		1S habitat		Ratio (2S/1S)
		Maximum $E(E)$	Bass position ²	Maximum $E(E)$	Bass position ²	
High light intensity (3,340 lux)						
Sigmoid	18	0.2458	9	0.1241	9	2.0
	36	0.2583	9	0.1292	9	2.0
Exponential	18	0.0223	9	0.0114	1	2.0
	36	0.0431	9	0.0223	1	1.9
Low light intensity (1.49 lux)						
Sigmoid	18	0.1995	9	0.1059	5	1.9
	36	0.3078	9	0.1586	7	1.9
Exponential	18	0.0124	9	0.0070	0	1.8
	36	0.0245	9	0.0138	1	1.8

¹Maximum distance traveled (inches) from an edge of vegetation by the largest-sized bluegill (4.9").

²Distance (inches) of a bass from an edge of vegetation at which maximum $E(E)$ s were estimated.

Table 5.—Maximum number of bluegills encountered ($E(E) \times 1,000$) and position of 8-inch bass at high and low light intensity in 2S and 1S habitat types, and ratios of maximum $E(E)$ s (2S/1S), assuming two distributions to describe different bluegill behaviors. Open water areas are 72" wide in the 2S habitat and 144" wide in the 1S habitat.

Bluegill distribution	Distance traveled ¹	2S habitat		1S habitat		Ratio (2S/1S)
		Maximum $E(E)$	Bass position ²	Maximum $E(E)$	Bass position ²	
High light intensity (3,340 lux)						
Sigmoid	18	0.1910	36	0.1773	1	1.1
	36	0.3846	36	0.3704	3	1.0
Exponential	18	0.0127	36	0.0113	0	1.1
	36	0.0251	36	0.0223	0	1.1
Low light intensity (1.49 lux)						
Sigmoid	18	0.0260	1	0.0288	1	0.9
	36	0.0503	2	0.0612	3	0.8
Exponential	18	0.0024	0	0.0024	0	1.0
	36	0.0047	0	0.0048	0	1.0

¹Maximum distance traveled (inches) from an edge of vegetation by the largest-sized bluegill (4.9").

²Distance (inches) of a bass from an edge of vegetation at which maximum $E(E)$ s were estimated.

Table 6.—Maximum number of bluegills encountered ($E(E) \times 1,000$) and position of 11-inch bass at high and low light intensity in 2S and 1S habitat types, and ratios of maximum $E(E)$ s (2S/1S), assuming two distributions to describe different bluegill behaviors. Open water areas are 72" wide in the 2S habitat and 144" wide in the 1S habitat.

Bluegill distribution	Distance traveled ¹	2S habitat		1S habitat		Ratio (2S/1S)
		Maximum $E(E)$	Bass position ²	Maximum $E(E)$	Bass position ²	
High light intensity (3,340 lux)						
Sigmoid	18	0.4059	36	0.3149	9	1.3
	36	0.5013	36	0.4239	17	1.2
Exponential	18	0.0754	36	0.0432	1	1.7
	36	0.1342	36	0.0809	1	1.7
Low light intensity (1.49 lux)						
Sigmoid	18	0.2273	4	0.3048	5	0.7
	36	0.3055	9	0.4494	9	0.7
Exponential	18	0.0260	0	0.0270	0	1.0
	36	0.0484	1	0.0519	1	0.9

¹Maximum distance traveled (inches) from an edge of vegetation by the largest-sized bluegill (4.9").

²Distance (inches) of a bass from an edge of vegetation at which maximum $E(E)$ s were estimated.

References

- Anderson, O. 1984. Optimal foraging by largemouth bass in structured environments. *Ecology* 65:851-861.
- Butler, M. J., IV. 1988. In situ observations of bluegill (*Lepomis macrochirus* Raf.) foraging behavior: the effects of habitat complexity, group size, and predators. *Copeia* 1988:939-944.
- Crowder, L. B., and W. E. Cooper. 1979. Structural complexity and fish-prey interactions in ponds: a point of view. Pages 2-10 in D. L. Johnson and R. A. Stein, editors. Response of fish to habitat structure in standing water. North Central Division of the American Fisheries Society, Special Publication 6.
- DeAngelis, D. L., S. M. Adams, J. E. Breck, and L. J. Gross. 1984. A stochastic predation model: application to largemouth bass observations. *Ecological Modelling* 24:25-41.
- Eggers, D. M. 1982. Planktivore preference by prey size. *Ecology* 63:381-390.
- Endler, J. A. 1986. Defense against predators. Pages 109-134 in M. E. Feder and G. V. Lauder, editors. Predator-prey relationships: perspectives and approaches from the study of lower vertebrates. The University of Chicago Press, Chicago, Illinois.
- Fujii, K., P. M. Mace, and C. S. Holling. 1978. A simple generalized model of attack by predators and parasites. University of British Columbia, Institute of Resource Ecology, Technical Report R-16, Vancouver, British Columbia, Canada.
- Gause, G. F. 1934. The struggle for existence. Hafner, New York, New York (reprinted 1964).
- Glass, N. R. 1971. Computer analysis of predation energetics in the largemouth bass. Pages 325-363 in B. C. Patten, editor. Systems analysis and simulation in ecology. Volume I. Academic Press, Inc., New York, New York.
- Gotceitas, V., and P. Colgan. 1987. Selection between densities of artificial vegetation by young bluegills avoiding predation. *Transactions of the American Fisheries Society* 116:40-49.
- Gotceitas, V., and P. Colgan. 1990. The effects of prey availability and predation risk on habitat selection by juvenile bluegill sunfish. *Copeia* 1990:409-417.
- Hassell, M. P. 1978. The dynamics of arthropod predator-prey systems. The Princeton University Press, Princeton, New Jersey.
- Hassell, M. P., J. H. Lawton, and J. R. Beddington. 1977. Sigmoid functional responses by invertebrate predators and parasitoids. *Journal of Animal Ecology* 46:249-262.
- Helfman, G. S. 1979. Fish attraction to floating objects in lakes. Pages 49-57 in D. L. Johnson and R. A. Stein, editors. Response of fish to habitat structure in standing water. North Central Division of the American Fisheries Society, Special Publication 6.
- Helfman, G. S. 1986. Behavioral responses of prey fishes during predator-prey interactions. Pages 135-156 in M. E. Feder and G. V. Lauder, editors. Predator-prey relationships: perspectives and approaches from the study of lower vertebrates. The University of Chicago Press, Chicago, Illinois.
- Holling, C. S. 1959. The components of predation as revealed by a study of small mammal predation of the European pine sawfly. *The Canadian Entomologist* 91:293-320.

- Holling, C. S. 1966. The functional response of invertebrate predators to prey density. *Memoirs of the Entomological Society of Canada* 48:1-86.
- Howick, G. L., and W. J. O'Brien. 1983. Piscivorous feeding behavior of largemouth bass: an experimental analysis. *Transactions of the American Fisheries Society* 112:508-516.
- Johnson, D. L., R. A. Beaumier, and W. E. Lynch, Jr. 1988. Selection of habitat structure interstice size by bluegills and largemouth bass in ponds. *Transactions of the American Fisheries Society* 117:171-179.
- Kerfoot, W. C., and A. Sih. 1987. Predation: direct and indirect impacts on aquatic communities. New England University Press, Hanover, New Hampshire.
- Lawrence, J. M. 1958. Estimated sizes of various forage fishes largemouth bass can swallow. *Proceedings of the Annual Conference of the Southeastern Association of Game and Fish Commissioners* 11:220-225.
- Marten, G. G. 1973. An optimization equation for predation. *Ecology* 54:92-101.
- Mittelbach, G. G. 1981. Foraging efficiency and body size: a study of optimal diet and habitat use by bluegills. *Ecology* 62:1370-1386.
- Neter, J., and W. Wasserman. 1974. *Applied linear statistical models*. Richard D. Irwin, Inc., Homewood, Illinois.
- Nyberg, D. W. 1971. Prey capture in the largemouth bass. *American Midland Naturalist* 86:128-144.
- O'Brien, W. J., N. A. Slade, and G. L. Vinyard. 1976. Apparent size as the determinant of prey selection by bluegill sunfish (*Lepomis macrochirus*). *Ecology* 57:1304-1310.
- Paloheimo, J. E. 1971a. On a theory of search. *Biometrika* 58:61-75.
- Paloheimo, J. E. 1971b. A stochastic theory of search: implications for predator-prey situations. *Mathematical Biosciences* 12:105-132.
- Savino, J. F., and R. A. Stein. 1982. Predator-prey interaction between largemouth bass and bluegills as influenced by simulated, submersed vegetation. *Transactions of the American Fisheries Society* 111:255-266.
- Savino, J. F., and R. A. Stein. 1989a. Behavioural interactions between fish predators and their prey: effects of plant density. *Animal Behaviour* 37:311-321.
- Savino, J. F., and R. A. Stein. 1989b. Behavior of fish predators and their prey: habitat choice between open water and dense vegetation. *Environmental Biology of Fishes* 24:287-293.
- Smith, K. D. 1993a. Vegetation-open water interface and the predator-prey interaction between largemouth bass and bluegills. Doctoral dissertation. The University of Michigan, Ann Arbor, Michigan.
- Smith, K. D. 1993b. Vegetation-open water interface and the predator-prey interaction between largemouth bass and bluegills: a field experiment. Michigan Department of Natural Resources, Fisheries Research Report 2000, Lansing, Michigan.
- Snyder, N. F. R. 1967. An alarm reaction of aquatic gastropods to intraspecific extract. Cornell University of Agriculture Experimental Station Memoirs 403, Cornell, New York.
- Stein, R. A., and J. J. Magnuson. 1976. Behavioral response of crayfish to a fish predator. *Ecology* 57:751-761.

- Watt, K. E. F. 1959. A mathematical model for the effect of densities of attacked and attacking species on the number attacked. *The Canadian Entomologist* 91:129-144.
- Webb, P. W. 1982. Avoidance responses of fathead minnow to strikes by four teleost predators. *Journal of Comparative Physiology* 147A:371-378.
- Webb, P. W. 1984. Body and fin form and strike tactics of four teleost predators attacking fathead minnow (*Pimephales promelas*) prey. *Canadian Journal of Fisheries and Aquatic Sciences* 41:157-165.
- Webb, P. W. 1986. Effect of body form and response threshold on the vulnerability of four species of teleost prey attacked by largemouth bass (*Micropterus salmoides*). *Canadian Journal of Fisheries and Aquatic Sciences* 43:763-771.
- Weihs, D., and P. W. Webb. 1984. Optimal avoidance and evasion tactics in predator-prey interactions. *Journal of Theoretical Biology* 106:189-206.
- Werner, E. E., J. F. Gilliam, D. J. Hall, and G. G. Mittelbach. 1983. An experimental test of the effects of predation risk on habitat use in fish. *Ecology* 64:1540-1548.
- Werner, E. E., and D. J. Hall. 1974. Optimal foraging and the size selection of prey by the bluegill sunfish (*Lepomis macrochirus*). *Ecology* 55:1042-1052.
- Werner, E. E., and D. J. Hall. 1988. Ontogenetic habitat shifts in bluegill: the foraging rate-predation risk trade-off. *Ecology* 69:1352-1366.
- Wetterer, J. K., and C. J. Bishop. 1985. Planktivore prey selection: the reactive field volume model vs. the apparent size model. *Ecology* 66:457-464.
- Wright, L. D. 1970. Forage size preference of the largemouth bass. *Progressive Fish-Culturist* 32:39-42.

Report approved by Richard D. Clark, Jr.
James S. Diana, Editor
Alan D. Sutton, Title Page Graphics

